

2014

PRODUCT
CATALOG

Viscometers & Rheometers
Texture Analysers
Powder Flow Testers

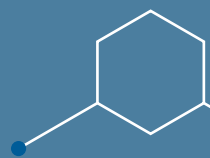
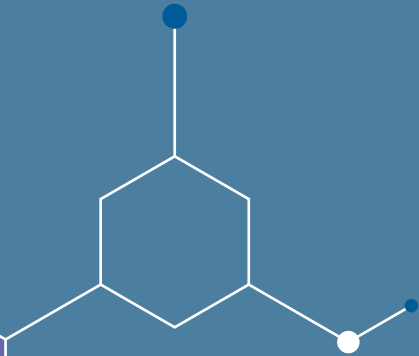

Index

- Why Measure Viscosity4
- Laboratory:** with software descriptions
 - DV3T Rheometer8
 - DV3T Extra Rheometer.....9
 - DV2T Viscometer.....10
 - DV2T Extra Viscometer11
 - DV-I Prime Viscometer12
 - DV-E Viscometer.....14
 - Dial Reading Viscometer15
 - Falling Ball Viscometer16
- Cone & Plate, Wells/Brookfield18
- CAP 2000+ and CAP 1000+20
- PVS Rheometer22
- RST Rheometers24
- RS Plus Portable Rheometer28
- YR-1 Rheometer.....30
- KU-2 Viscometer31
- BF-35 Viscometer31
- Temperature Control**
 - Water Baths33
 - Thermosel36
- Accessories**
 - Small Sample Adapter38
 - Enhanced UL Adapter.....40
 - Helipath Stand.....42
 - Vane Spindles43
 - Adapters (DIN, Spiral)44
 - Spindles, Cups, Chambers45
 - Quick Connect49
 - Instrument Stands.....50
 - Ball Bearing & EZ-Lock Options.....50
 - Protective Covers & Decals.....51
 - Dymo Label Writer51
 - Viscosity Standards52
- Texture Analyzer**
 - What is Texture Analysis?56
 - CT3 Texture Analyzer58
- Powder Flow Tester**
 - What is Powder Flow Testing?68
 - PFT Powder Flow Tester70
- Brookfield Systems**
 - Starch, Chocolate, Paints/Coatings/Ink ...74
 - Asphalt, Personal Care Products75
 - Electronics Paste75
 - Pharmaceutical, Petroleum76
 - Sauces & Dressings76
 - Construction Materials.....77
 - Dairy Products, Adhesives77
- Process**
 - Why Process?.....80
 - AST-100 Viscometer Series82
 - TT-100 Viscometer Series82
 - Viscosel Series (VTE & VTA).....83
 - PV-100 & KV-100 Viscometers83
- General**
 - Testing & Consulting Services84
 - Calibration and Certification85
 - IQ, OQ, PQ85
 - Education.....86
 - Help & Resources.....87
 - Glossary88
 - Dealers.....89

This Years Spotlight: Rheometers

Rheometer vs. Viscometer

“How do I know if I need a rheometer instead of a viscometer?”. It’s a question frequently asked by our customers at trade shows, in phone calls and queries through our website. Regardless of whether the product is a liquid, cream, paste, or solid, the manufacturing process must transfer raw ingredients through multiple stages to create a consistent, finished product. The ability to pump, mix, transfer, store and fill the product are processes that rely on proper rheological analysis. Both rheometers and viscometers play a pivotal role, but which one is right for you? Here are some important considerations to take into account:

MATERIAL AND TYPE OF MEASUREMENT

The answer lies not only in the data you are trying to obtain, but also the material itself. Viscous materials, such as thick ointments, are good candidates for testing by a controlled stress rheometer. The controlled stress mode can make a direct measurement of yield stress, the force required to start a material flowing. This measurement can be equated with the startup torque in a motor that drives the pump on the production floor. It is also a useful measurement to quantify the squeezing force applied by the end user to get the product out of the tube.

Viscometers provide controlled rate measurements and give “flow curve” information characterizing the resistance of the material when you try to make it flow. For most liquids and semi-solids, viscosity decreases as shear rate increases; this is equivalent in most cases to making the material flow faster. One viscosity value is typically selected as the control point for use by QC in material production batches. However, multiple point measurements for highly shear thinning materials — such as medical ointments — are typically made to confirm that the material’s flow behavior is acceptable to both manufacturing and the end user.

COAXIAL SPINDLE	SHEAR RATE (sec ⁻¹)	INSTRUMENT
Dip Coating (paints confectionery)	10 ¹ -10 ²	Viscometer, Rheometer
Mixing/Stirring (manufacturing liquids)	10 ¹ -10 ³	Viscometer, Rheometer
Spraying/Brushing (paints, fuel atomization)	10 ³ -10 ⁴	Rheometer
High Speed Coating (paper)	10 ⁵ -10 ⁶	Rheometer

Additional examples can be found on our website.

The following page presents new choices from Brookfield which show how rheometers are integrating the advanced technology of the electronics industry.

For additional discussion on rheometers and viscometers, consult our “More Solutions to Sticky Problems” booklet or visit: www.brookfieldengineering.com

NEW RST Series of Touch Screen Rheometers: High End Performance at a Low End Cost

Brookfield welcomes three new instruments into its touch screen family of rheometers. The new RST Series offers the quickest and most comprehensive capability for making rheological measurements, whether it's single point viscosity for QC or complete flow curve analysis for R&D. The RST is the only instrument that can perform all of the following tests: viscoelastic modulus, yield stress, viscosity vs. shear rate profile, thixotropy calculation, creep behavior, recovery after flow, and temperature sensitivity.

Several striking features identify the signature capability provided by RST relative to other instruments in its class:

- Widest torque range to handle the broadest range of sample materials
- Greatest versatility with largest range of shear rates and spindle geometries
- Highest flexibility through its sturdy rugged design which permits RST to work in a lab environment or on the production floor

All RST models come with the standard option for 21CFR compliance, including controlled user access and data integrity/security. Other capabilities include:

- 11 memory slots for structured multi-step test programs
- Internal memory for test data storage
- Choice of USB or RS232 for data output and PC control
- Quick connect coupling for rapid spindle attachment

Affordability is the final, and perhaps most satisfying, characteristic that distinguishes RST from other rheometers. No other instrument offers so much capability at such a reasonable price. But then again, RST is a Brookfield! (p24-29)



RST-CPS Rheometer

Cone/Plate model is available with optional automatic gap adjustment feature



RST-CC Rheometer

Coaxial Cylinder DIN Geometries for single point QC or full rheological profiling



RST-SST Rheometer

Soft Solids Tester for pastes, slurries and materials with particulates



Also available in a cone/plate model for small sample size or broader shear rate testing.

DV3T Rheometer Graphing Capabilities

MAY BE JUST WHAT YOUR PROCESS NEEDS

Q: What's the "best-kept secret" of our recently introduced DV3T Rheometer?

A: It's ability to provide real time, on screen graphing of test data.

Q: Why is this important?

A: Having the immediate knowledge of a product's viscosity flow behavior can have a huge impact on quality and profitability as problems can be addressed immediately, eliminating product waste and saving valuable time.

Q: Why should you consider the DV3T Rheometer over a viscometer?

A: The DV3T with touch screen technology has more measurement capability, including yield stress data. The DV3T allows for quick, single-point tests, just like expensive rheometers without the high price and steep learning curve for technicians. Its the ideal "all-in-one" instrument for busy QC labs as well as demanding R&D departments investigating flow behavior. (p8-9)



viscose rheome

eters
eters



Why measure viscosity?

The ability to gather data on a material's viscosity behavior gives manufacturers an important "product dimension." Knowledge of a material's rheological characteristics is valuable in predicting its pourability, its performance in a dipping or coating operation, or the ease with which it may be handled, processed, or used. The interrelation between rheology and other product dimensions often makes the measurement of viscosity the most sensitive or convenient way of detecting changes in color, density, stability, solids content, and molecular weight.

Why Choose Brookfield?

Ease of use, flexibility, reliable performance and quality of service have made Brookfield Viscometers favorites all over the world. All Brookfield Viscometers are accurate within $\pm 1.0\%$ of the range in use and have a reproducibility within $\pm 0.2\%$. Test results can be duplicated anywhere in the world when the same model instrument is used.

Price

Choices for Instrumentation

This chart shows the Brookfield family of Laboratory Viscometers and Rheometers at a glance. This will help to give you a general idea of what is available before making a decision. The horizontal axis indicates performance capability and features while the vertical axis addresses price level.

Need to measure viscosity in-line?
Brookfield also offers a complete line of process viscometers. (p78)



Dial Reading
• Torque



DV-E
• Calculates Viscosity
• Torque



DV-I Prime
• Optional Temp Probe
• Calculates Viscosity
• Torque



DV-I Prime Cone/Plate
• Small Sample Size
• Defined Shear Rate



DV2T
• Touch Screen Interface
• Temp Probe
• Data / User Security
• PC Control
• Calculates Viscosity
• Torque



DV2T Cone/Plate
• Small Sample Size
• Defined Shear Rate



DV3T
• Touch Screen Interface
• Real Time Graphing
• Temp Probe
• Data / User Security
• PC Control
• Calculates Viscosity
• Torque
• Yield Stress



DV3T Cone/Plate
• Small Sample Size
• Defined Shear Rate



CAP 2000+ Cone/Plate
• Broad Shear Rate Range
• Peltier Plate Temp Control
• RS 232 (PC control)



RST Coaxial Cylinder
• Controlled Stress & Rate
• Yield Stress
• Stand Alone Programmable
• Temp Probe
• USB & RS232
• Calculates Viscosity
• Torque



RST Cone/Plate
• Peltier Plate



PVS Rheometer
• Pressurized Sample Chamber
• Controlled Rate
• Temp Probe
• RS232/USB
• Calculates Viscosity
• Torque

Performance

SPECIAL PURPOSE INSTRUMENTS



YR-1 Yield Test Rheometer
• Yield Stress



KU-2 Viscometer
• KREBS Viscosity
• Required for Paint and Coatings



CAP 1000+ Cone/Plate
• Single Shear Rate
• Required for Paints and Coatings



RST Soft Solids Tester
• Yield Stress
• Creep
• Recovery



Falling Ball Viscometer
• Viscosity
• Used for QC & Academic Institutions

Brookfield also offers several special purpose instruments which are used to perform a specific type of test or are used to evaluate certain types of materials.

Questions to Consider

1. What is the viscosity range of your material: Low, medium, high?
2. What rotational speeds or shear rates are important?
3. How much sample is available for testing?
4. Is temperature measurement/control necessary?
5. Do you need to record the viscosity data?

The Selection Method

The Model Selection Table (shown at right) shows detailed information on standard Brookfield Viscometers/Rheometers, including the Dial Reading, DV-E, DV-I Prime, DV2T, and DV3T. The Applications Table (shown at lower right) shows information on typical applications of the standard Brookfield viscosity ranges. There may be industry or supplier/vendor specifications that you need to duplicate. Before making a final selection, we suggest that you confer with people in your industry to find out which Brookfield Viscometer they are using so that your data can be correlated. More application details may be found throughout this catalog for other Brookfield instruments on the following pages:

CAP1000+/2000+ Viscometers (p18-19) *YR-1 Rheometer* (p30)
PVS Rheometer (p22-23) *KU-2 Viscometer* (p31)
R/S Plus series Rheometers (p24-28) *Texture Analyzer* (p56-61)

In addition, you may wish to call us and discuss your application or refer to our extensive library of technical papers which covers a complete spectrum of applications. We can also test your materials at Brookfield to recommend the instrument most suitable for your application.

Spindles

Standard Brookfield Viscometers/Rheometers are supplied with a standard spindle set constructed of stainless steel (#302). Additional spindle options are available in #316 stainless steel or with Teflon coating for increased corrosion resistance. Other spindles and accessories are also available. (p45-48)

Cylindrical Spindles

Cylindrical spindles are particularly valuable when measuring non-Newtonian fluids and are applicable to any Brookfield Viscometer model with the use of appropriate range tables. Cylindrical spindles may be substituted for standard spindles upon request.



Need additional assistance? Our website, www.brookfieldengineering.com, contains additional information on the measurement selection process as well as detailed application notes.

Model Selection Table Brookfield Standard Viscometers/Rheometers

** MODEL	Min. $\text{cP}/\text{mPa}\cdot\text{s}$ VISCOSITY RANGE	Max. $\text{cP}/\text{mPa}\cdot\text{s}$ VISCOSITY RANGE	NUMBER OF SPEEDS	# of Spindles Supplied
LOW VISCOSITY				
LVT	1*	2 M	8	4
LVDV-E	1*	2 M	18	4
LVDV-IP	1*	2 M	18	4
DV2TLV	1*	6 M	200	4
DV3TLV	1*	6 M	2600	4
MEDIUM VISCOSITY				
RVT	100	8 M	10	6
RVDV-E	100	13 M	18	6
RVDV-IP	100	13 M	18	6
DV2TRV	100	40 M	200	6
DV3TRV	100	40 M	2600	6
HIGH VISCOSITY				
HAT	200	16 M	10	6
HADV-E	200	26 M	18	6
HADV-IP	200	26 M	18	6
DV2THA	200	80 M	200	6
DV3THA	200	80 M	2600	6
HBT	800	64 M	10	6
HBDV-E	800	104 M	18	6
HBDV-IP	800	104 M	18	6
DV2THB	800	320 M	200	6
DV3THB	800	320 M	2600	6

** Standard torque range values M = 1 millin

* Minimum ranges can be extended to as low as 1 cP with the use of Brookfield Accessories

Applications Table

Consider application and viscosity range when selecting model (LV, RV, HA, HB)

LV SERIES – LOW VISCOSITY

Adhesives (solvent base)	Inks	Photo Resist
Biological Fluids	Juices	Polymer Solutions
Chemicals	Latex	Rubber Solutions
Cosmetics	Oils	Solvents
Dairy Products	Paints and Coatings	
Hot Waxes	Pharmaceuticals	

RV SERIES – MEDIUM VISCOSITY

Adhesives (hot melt)	Gums	Plastisols
Asphalt (SHRP)	Inks (screen printing)	Starches
Ceramic Slurries	Organisols	Surface Coatings
Creams	Paints	Toothpaste
Dairy Products	Paper Coatings	Varnish
Food Products	Paper Pulp	

HA/HB SERIES – HIGH VISCOSITY

Asphalt	Pastes
Caulking Compounds	Peanut Butter
Chocolate	Putty
Epoxies	Roofing Compounds
Gels	Sealants
Inks (ballpoint, offset, lithographic)	Sheet Molding Compound
Molasses	Tars

DV3T™ Rheometer

the all-in-one tool for measuring viscosity and yield stress

7-inch Full Color Touch Screen Display

- New User Interface
- Enhanced Controls
- Real Time Graphing
- Supports Multiple Languages

Displayed Info:

- Viscosity (cP or mPa•s)
- Temperature (°C or °F)
- Shear Rate/Stress
- % Torque
- Speed/Spindle
- Step Program Status
- Math Model Calculations

Built-in math models for data analysis in stand-alone mode. E.g. Casson, Bingham, Power Law, Thix Index

Enhanced Security

- Customizable User Access
- Date and Time Stamp File
- Password Access
- Portable Log-in Settings

Built-In Options

- Math Modeling
- Temperature Control
- Yield Tests
- Programmable QC Limits/Alarms

Analyze characteristics such as yield stress, flow curves (mixing, pumping, spraying), leveling and recovery

USB PC Interface provides optional computer control and automatic data collection capability

Convenient Bubble Level

Internal Data Storage: 150 MB



Integrated Temperature Control with connection to Brookfield TC series Baths and AP controller or Brookfield Thermosel System.

Stand-alone programming or download custom test programs with PG Flash Software.

Built-in RTD Temperature Probe

Accuracy: ±1.0% of range

- Displayed with test data

Repeatability: ±0.2%

What's Included?

Instrument

6 spindles (RV/HA/HB) (p45)
or 4 spindles (LV) (p45)

PG Flash Software ▶

RTD Temperature Probe

Spindle Guard Leg*

Lab Stand (Model G) (p50)

Convenience Pack

USB Flash Drive, Stylus, Cleaning Cloth, Screen Protectors

Carrying Case

*Not applicable to HA or HB torque models

Optional Accessories

RheocalcT Software ▶

Label Printer (p51)

Vane Spindles (p43 & 48)

Ball Bearing Suspension (p50)

Viscosity Standards (p52)

RV/HA/HB-1 Spindle (p45)

EZ-Lock Spindle Coupling System (p50)

Quick Action Lab Stand (p50)

Temperature Bath (p33-35)

Small Sample Adapter (p38)

UL Adapter (p40)

Thermosel (p36)

Helipath Stand with T-bar Spindles (p42)

Spiral Adapter (p44)

DIN Adapter (p44)

Quick Connect/Extension Links (p49)

MODEL	VISCOSITY RANGE cP(mPa•s)		SPEEDS (2600 available)	
	Min.	Max.	RPM	Number of Increments
DV3TLV	1†	6M	.01-250	2.6K
DV3TRV	100††	40M	.01-250	2.6K
DV3THA	200††	80M	.01-250	2.6K
DV3THB	800††	320M	.01-250	2.6K
DV3T5xHB	4K	1.6B	.01-250	2.6K

† 1 cP achieved with UL Adapter accessory. 15 cP on LV with standard spindles.
†† Minimum viscosity is achieved with optional RV/HA/HB-1 spindle.
B = 1 billion M = 1 million K = 1 thousand cP = Centipoise
mPa•s = Millipascal•seconds

PG Flash Software Included

PROGRAM GENERATOR SOFTWARE FOR CUSTOMIZING
TEST CRITERIA FOR ROUTINE PRODUCT QC

This exclusive Brookfield software allows you to create repeatable custom tests on your PC! Once the program (up to 25 steps) is created, it can be downloaded to a supplied USB flash drive and then uploaded to any DV3T Viscometer.



PG Flash allows users to create repeatable custom tests with all of the built-in options on the DV3T plus the addition of multiple program lines (up to 25 steps). Create the program on the PC and download to a USB Flash Drive. Upload the program from the USB Flash Drive to the DV3T.

RheocalcT Software Optional

GET TOTAL CONTROL OF YOUR INSTRUMENT AND TEST PARAMETERS

Automatically control and collect data with RheocalcT and a dedicated computer. RheocalcT can analyze data, generate multiple plot overlays, print tabular data, run math models and perform other time-saving routines. Up to five comparison data sets can be plotted and saved. Other features include:

- Wizards to guide you through the creation of common tests
- Yield Testing, alone, or in conjunction with other viscosity measurements
- Secure 21CFR features including multiple logins, access levels, digital signatures, and data storage in a password-protected database
- Looping functions for repetitive tasks
- Averaging of collected data by step or whole test
- Math models: Bingham, Casson, Casson NCA/CMA, Power Law, IPC Paste, Herschel-Bulkley, Thix Index

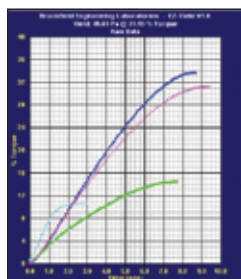

TORQUE RANGE **SHEAR STRESS RANGE**

Pa dyne/cm²

	Contact Brookfield	
LV	.5-100	5-1K
RV	1-200	10-2K
HA	4-800	40-8K
5xHB	20-4K	200-40K

Yield tests can be performed with the use of optional vane spindles.



DV3TCP

The DV3T is available in a Wells/Brookfield Cone & Plate Version
Must be ordered when instrument is first purchased. (p18)



DV3T with Optional Vane Spindles

DV3T Rheometers have a built-in yield stress measurement capability that determines the stress required to initiate flow of slow moving or paste materials. Vane spindles can be immersed into a material without destroying the underlying structures that contribute to yield. The DV3T offers test parameters that create a specific yield test protocol that can be utilized for QC testing or research.

DV3T Extra

Includes our ball bearing suspension system, EZ-Lock Spindle Coupling System, Quick Action Lab Stand and FREE RheocalcT software.

DV2T™ Viscometer

our most versatile continuous sensing viscometer

5-inch Full Color Touch Screen Display

- New User Interface
- Enhanced Controls
- Real Time Trend Indicator
- Supports Multiple Languages

Displayed Info:

- Viscosity (cP or mPa•s)
- Temperature (°C or °F)
- Shear Rate/Stress
- % Torque
- Speed/Spindle
- Step Program Status

Enhanced Security

- Customizable User Access
- Date and Time Stamp File
- Password Access
- Portable Log-in Settings

Built-in Options

- Timed Tests
- Data Averaging
- Programmable QC Limits/Alarms
- Customizable Speed/Spindle Lists
- Test Based User Instructions
- On Screen Data Comparison

Auto Range Showing

- Maximum viscosity measured with Spindle/Speed combination

USB PC Interface provides optional computer control and automatic data gathering capability



Convenient Bubble Level

Download custom test programs with PG Flash Software (included with instrument)

Accuracy: ±1.0% of range
- Displayed with test data

Repeatability: ±0.2%

Built-in RTD Temperature Probe

Internal Data Storage: 150 MB

What's Included?

Instrument

6 spindles (RV/HA/HB) (p45)
or 4 spindles (LV) (p45)

PG Flash Software ▶

RTD Temperature Probe

Spindle Guard Leg*

Lab Stand (Model G) (p50)

Convenience Pack

USB Flash Drive, Stylus, Cleaning Cloth, Screen Protectors

Carrying Case

*Not applicable to HA or HB torque models

Optional Accessories

RheocalcT Software ▶

Label Printer (p51)

Vane Spindles (p43 & 48)

Ball Bearing Suspension (RV/HA/HB) (p50)

Viscosity Standards (p52)

RV/HA/HB-1 Spindle (p45)

EZ-Lock Spindle Coupling System (p50)

Quick Action Lab Stand (p50)

Temperature Bath (p33-35)

Small Sample Adapter (p38)

UL Adapter (p40)

Thermosel (p36)

Helipath Stand with T-bar Spindles (p42)

Spiral Adapter (p44)

DIN Adapter (p44)

Quick Connect/Extension Links (p49)

MODEL	VISCOSITY RANGE cP(mPa•s)		SPEEDS (200 available)	
	Min.	Max.	RPM	Number of Increments
DV2TLV	1†	6M	.1-200	200
DV2TRV	100††	40M	.1-200	200
DV2THA	200††	80M	.1-200	200
DV2THB	800††	320M	.1-200	200

† 1 cP achieved with UL Adapter accessory. 15 cP on LV with standard spindles.

†† Minimum viscosity is achieved with optional RV/HA/HB-1 spindle.

M = 1 million cP = Centipoise mPa•s = Millipascal•seconds

PG Flash Software Included

PROGRAM GENERATOR SOFTWARE FOR CUSTOMIZING
TEST CRITERIA FOR ROUTINE PRODUCT QC

This exclusive Brookfield software allows you to create repeatable custom tests on your PC! Once the program (up to 25 steps) is created, it can be downloaded to a supplied USB flash drive and then uploaded to any DV2T Viscometer.



PG Flash allows users to create repeatable custom tests with all of the built-in options on the DV2T plus the addition of multiple program lines (up to 25 steps). Create the program on the PC and download to a USB Flash Drive. Upload the program from the USB Flash Drive to the DV2T.

RheocalcT Software Optional

GET TOTAL CONTROL OF YOUR INSTRUMENT AND TEST PARAMETERS

Automatically control and collect data with RheocalcT and a dedicated computer. RheocalcT can analyze data, generate multiple plot overlays, print tabular data, run math models and perform other time-saving routines. Up to five comparison data sets can be plotted and saved. Other features include:

- Wizards to guide you through the creation of common tests
- Secure 21CFR features including multiple logins, access levels, digital signatures, and data storage in a password-protected database
- Looping functions for repetitive tasks
- Averaging of collected data by step or whole test
- Math models: Bingham, Casson, Casson NCA/CMA, Power Law, IPC Paste, Herschel-Bulkley, Thix Index



DV2TCP

The DV2T is available in a Wells/Brookfield Cone & Plate Version
Must be ordered when instrument is first purchased. (p18)



DV2T EXTRA™ Viscometer

The "EXTRA" combines all the versatile viscosity testing capabilities of a DV2T with time and money-saving features such as a durable ball bearing suspension system, EZ-Lock Spindle Coupling, Quick Action Lab Stand and FREE Rheocalc T Software.

DV-1™ Prime Viscometer

The only viscometer in its class to offer continuous sensing and data display!

Displayed Info:

- Viscosity (cP or mPa•s)
 - % Torque
 - Speed/Spindle
 - Temperature (°C or °F)
- if optional RTD Temperature Probe is installed

RS-232 PC interface for use with optional Wingather Software

Analog outputs for recording torque and temperature

18 speeds provide great range capability

Direct access to time measurement function (time to torque, time to stop)

Accuracy: ±1.0% of range

Repeatability: ±0.2%

Output connection to printer

Auto Range Showing

- Full Scale Range (FSR) at 100%
- Maximum viscosity measured with Spindle/Speed combination

Scroll Keys for Simple Selection of Speed & Spindle

Optional RTD Temperature Probe DVP-94Y

Instrument must be configured upon purchase.

Temperature off-set capability to ±1°C



What's Included?

- Instrument
 - 6 spindles (RV/HA/HB) (p45) or 4 spindles (LV) (p45)
 - Spindle Guard Leg*
 - Lab Stand (Model S) (p50)
 - Carrying Case
- *Not applicable to HA or HB torque models

Optional Accessories

- Wingather Software ▶
- RTD Temperature Probe
- Ball Bearing Suspension (RV/HA/HB) (p50)
- Viscosity Standards (p52)
- RV/HA/HB-1 Spindle (p45)
- Quick Action Lab Stand (p50)
- EZ-Lock Spindle Coupling System (p50)
- Temperature Bath (p33-35)
- Small Sample Adapter (p38)
- UL Adapter (p40)
- Thermosel (p36)
- Helipath Stand with T-bar Spindles (p42)
- Spiral Adapter (p44)
- DIN Adapter (p44)
- Quick Connect/Extension Links (p49)
- Vane Spindles (p43 & 48)
- Protective Keypad Covers (p51)

MODEL	VISCOSITY RANGE cP(mPa•s)		SPEEDS	
	Min.	Max.	RPM	Number of Increments
LVDV-IP	1*	2M	.3-100	18
RVDV-IP	100	13M	.3-100	18
HADV-IP	200	26M	.3-100	18
HBDV-IP	800	104M	.3-100	18

* Minimum ranges can be extended to as low as 1 cP with the use of Brookfield Accessories

** Standard torque range values

M = 1 million cP = Centipoise mPa•s = Millipascal•seconds

Wingather Software Optional

DATA COLLECTION SOFTWARE TO COLLECT, ANALYZE AND RECORD TEST DATA

Wingather software provides an easy way to gather data and plot graphs while creating permanent test records. Data can be saved in the program or exported to Excel.

- Automates data collection to save time
- Reduces operator error
- Math modeling for yield stress calculations, plastic index
- Plot up to four data sets for comparisons

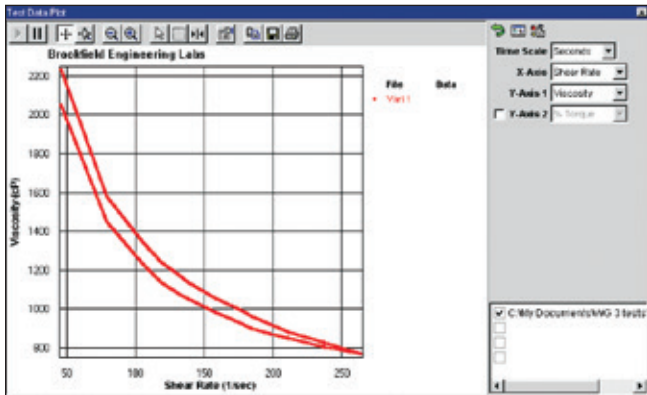

The screenshot shows the 'Test Data Grid' window with a table of test data. The table has 8 columns: Viscosity, Speed, % Torque, Shear Stress, Shear Rate, Temperature, Time Interval, and Date/Time. The data shows a clear inverse relationship between shear rate and viscosity.

Viscosity	Speed	% Torque	Shear Stress	Shear Rate	Temperature	Time Interval	Date/Time
2096.10	1.00	39.9	1.40	1.29	34.4	00:00.4	01/12/2007 12:16:17
698.29	1.50	29.8	1.35	1.94	34.1	00:26.2	01/12/2007 12:16:44
604.32	2.00	34.5	1.56	2.50	34.0	00:16.6	01/12/2007 12:17:01
530.04	2.50	37.7	1.73	3.23	33.6	00:46.4	01/12/2007 12:17:49
427.64	3.00	36.5	1.65	3.87	33.5	00:11.3	01/12/2007 12:18:01
289.43	5.00	41.2	1.87	6.45	33.5	00:00.2	01/12/2007 12:18:10
244.28	6.00	41.7	1.89	7.74	33.4	00:10.4	01/12/2007 12:18:21
175.74	10.00	56.0	2.27	12.90	33.3	00:00.4	01/12/2007 12:18:30
152.90	12.00	52.2	2.37	15.40	33.2	00:14.4	01/12/2007 12:18:46
105.27	20.00	59.9	2.72	25.00	33.1	00:12.4	01/12/2007 12:18:59
79.32	30.00	67.7	3.07	38.70	33.0	00:09.2	01/12/2007 12:19:09
55.54	50.00	79.0	3.38	64.50	32.9	00:05.9	01/12/2007 12:19:16
49.97	60.00	85.3	3.83	77.40	32.9	00:06.6	01/12/2007 12:19:24



DV-I Prime CP

The DV-I Prime is available in a Wells/Brookfield Cone & Plate Version

Must be ordered when instrument is first purchased. (p18)

DV-E™ Viscometer

our lowest cost digital viscometer

No calculations required

- Direct reading of viscosity in cP or mPa•s

Displayed Info:

- Viscosity (cP or mPa•s)
- % Torque
- Speed/Spindle

Easy-to-Use:

- Flip a switch
- Turn a knob

Spindle/Speed Selection

Flip to "Speed"

- Turn the knob
- Choose RPM

Flip to "Spindle"

- Turn the knob
- Choose spindle

Auto Range

push for determining full scale range (FSR) viscosity

18 Speeds for complete range capability

Accuracy: ±1.0% of range

Repeatability: ±0.2%



What's Included?

- Instrument
 - 6 spindles (RV/HA/HB) (p45) or 4 spindles (LV) (p45)
 - Spindle Guard Leg*
 - Lab Stand (Model A) (p50)
 - Carrying Case
- *Not applicable to HA or HB torque models

Optional Accessories

- Viscosity Standards (p52)
- RV/HA/HB-1 Spindle (p45)
- Quick Action Lab Stand (p50)
- Temperature Bath (p33-35)
- Small Sample Adapter (p38)
- UL Adapter (p40)
- Thermosel (p36)
- Helipath Stand with T-bar Spindles (p42)
- Spiral Adapter (p44)
- DIN Adapter (p44)
- Quick Connect/Extension Links (p49)
- Vane Spindles (p43 & 48)

MODEL	VISCOSITY RANGE cP(mPa•s)		SPEEDS	
	Min.	Max.	RPM	Number of Increments
LVDV-E	1†	2M	.3-100	18
RVDV-E	100††	13M	.3-100	18
HADV-E	200††	26M	.3-100	18
HBDV-E	800††	104M	.3-100	18

† 1 cP achieved with UL Adapter accessory. 15 cP on LV with standard spindles.
 †† Minimum viscosity is achieved with optional RV/HA/HB-1 spindle.
 M = 1 million cP = Centipoise mPa•s = Millipascal•seconds

Dial Reading Viscometer

our original...over 75 years!

The Worldwide Standard
Viscometer

Easy-to-Select Speeds

Electronic Drive
means quiet,
reliable operation

Analog display
- Shows % Torque
- Use Factor Finder
to convert reading to centipoise

Simple-to-use,
easy setup

2-Year Limited Warranty

Available in explosion proof
U.L. Class 1, Division 1,
Group D locations
(w/o Electronic Drive)

Accuracy: $\pm 1.0\%$ of range

Repeatability: $\pm 0.2\%$



What's Included?

Instrument
6 spindles (RV/HA/HB) (p45)
or 4 spindles (LV) (p45)
Spindle Guard Leg*
Lab Stand (Model A) (p50)
Carrying Case
*Not applicable to HA or HB torque models

Optional Accessories

Viscosity Standards (p52)
RV/HA/HB-1 Spindle (p45)
Quick Action Lab Stand (p50)
Temperature Bath (p33-35)
Small Sample Adapter (p38)
UL Adapter (p40)
Thermosel (p36)
Helipath Stand with T-bar Spindles (p42)
Spiral Adapter (p44)
DIN Adapter (p44)
Quick Connect/Extension Links (p49)
Vane Spindles (p43 & 48)

MODEL	VISCOSITY RANGE cP(mPa•s)		SPEEDS	
	Min.	Max.	RPM	Number of Increments
LVT	1†	2M	.3-60	8
RVT	100††	8M	.5-100	10
HAT	200††	16M	.5-100	10
HBT	800††	64M	.5-100	10

† 1 cP achieved with UL Adapter accessory. 15 cP on LV with standard spindles.
†† Minimum viscosity is achieved with optional RV/HA/HB-1 spindle.
M = 1 million cP = Centipoise mPa•s = Millipascal*seconds



*Easy Speed
Adjustment
and On/Off
Control*

Falling Ball Viscometer

...Newtonian measurements made simple and easy!

The Brookfield Falling Ball Viscometer uses the simple — but precise — Höppler principle to measure the viscosity of Newtonian liquids by measuring the time required for a ball to fall under gravity through a sample-filled tube.

Set of six balls to test a wide variety of samples

Connection to circulating bath for temperature control of sample

Temperature Probe

Pivot bearing allows for quick and easy tube rotation for repeat test

Model KF40 (shown) variable angle for non-newtonian fluids

Model KF30 (also available) fixed angle complies with DIN 53015

Viscosity Range:
0.5 to 70,000
mPa•s (cP)

Accuracy:
0.5% to 2.0%
(depending on ball used)



What's Included?

- Instrument
- Set of six (6) balls
- Temperature Probe
- Carrying Case

Optional Accessories

- Temperature Bath (p33-35)
- Viscosity Standards (p52)
- Special Temperature Probes

Applications

- Beverages
- Coatings
- Cosmetics
- Detergents
- Food
- Paint
- Petroleum Products
- Pharmaceuticals
- Polymers
- Soap

How It Works

The Falling Ball Viscometer is based on the measuring principle by Höppler for simple but precise dynamic viscosity measurement of transparent Newtonian fluids. The basic concept is to measure the elapsed time required for the ball to fall under gravity through a sample-filled tube inclined at an angle*. The tube is mounted on a pivot bearing which quickly allows rotation of the tube 180 degrees, thereby allowing a repeat test to run immediately. Three measurements are taken and the average time it takes for the ball to fall is the result. A conversion formula turns the time reading into a final viscosity value.

The Falling Ball Viscometer is used for quality control in various industries as well as in academic institutions to illustrate scientific method. The ease of use and straightforward method for recording time measurements ensures meaningful test results.

*Model KF30 has a fixed angle of 80 degrees; Model KF40 can be angled at 50, 60, 70 and 80 degrees.

SPECIFICATIONS

Viscosity Range: 0.5 mPa•s (cP) to 70,000 mPa•s (cP)

Accuracy: 0.5% - 2.0% depending on choice of ball

Ball set Material of Construction:

Balls 1 and 2: Boron Silicate Glass

Balls 3 and 4: Nickel-iron

Balls 5 and 6: Steel

Ball Diameter: 11.0 mm to 15.81 mm

Fall Time of Ball in Measurement: 30 to 300 seconds**

Length of Measurement Zone in the Tube: 100 mm

Operating Temperature Range: -5°C to +150°C

Sample Tube Volume: 40mL

Viscometer Dimensions: 180 x 220 x 330 mm

**Falling times greater than 300 seconds allow measurement of liquids above 70,000 mPa•s (cP)



Ball Set with Case

The Falling Ball Viscometer comes complete with a set of six (6) balls. See Specifications for material construction.



KF40 with Bath

Use with a Brookfield Circulating Bath permits rapid temperature control of sample for more accurate and repeatable results.

Wells/Brookfield™ Cone & Plate

for small samples

Determine absolute viscosity
of small samples (0.5 – 2.0 mL)

Available in these models

- DV3T Rheometer
- DV2T Viscometer
- DV-I Prime Viscometer

Accuracy: ±1.0% of range

Repeatability: ±0.2%

Electronic Gap Adjustment™

- Simplified setup
- Accurate
- Easy-to-use

RTD Temperature Sensor

in Sample Cup (Optional)
provides direct measurement of
sample temperature

Control Sample Temperature

using a Brookfield circulating
water bath (p27)

Rapid temperature control

due to small sample size

Temperature Range:

- 1°C to 100°C

Precise shear rates

for determining a material's flow
curve behavior



What's Included?

- Instrument
- Lab Stand (p50)
- Choice of one Cone Spindle (p46)
- Sample Cup (p46)

Optional Accessories

- Embedded Temperature Probe
in Sample Cup (p46)
- Luer and Purge fittings
- Ball Bearing Suspension (p50)
- Additional Cone Spindles (p46)
- Viscosity Standards (p52)
- Circulating Temperature Bath (p33-35)
- RheocalcT Software ▶
(DV3T & DV2T only)
- Wingather Software ▶
(DV-I Prime only)
- Protective Keypad Covers (p51)

Viscosity Range* cP(mPa*s)

MODEL	Cone Spindle: CPA-40Z Sample Volume: .5mL Shear Rate (sec ⁻¹): 7.5N		Cone Spindle: CPA-41Z Sample Volume: 2.0mL Shear Rate (sec ⁻¹): 2.0N		Cone Spindle: CPA-42Z Sample Volume: 1.0mL Shear Rate (sec ⁻¹): 3.84N		Cone Spindle: CPA-51Z Sample Volume: .5mL Shear Rate (sec ⁻¹): 3.84N		Cone Spindle: CPA-52Z Sample Volume: .5mL Shear Rate (sec ⁻¹): 2.0N		SPEEDS			
	.1 - 3K	.5 - 11K	.2 - 6K	2 - 48K	3 - 92K	.01 - 250	2.6K	.2 - 3K	.6 - 11K	.3 - 6K	2 - 48K	4 - 92K	.01 - 200	200
DV3TLVCP	.1 - 3K	.5 - 11K	.2 - 6K	2 - 48K	3 - 92K	.01 - 250	2.6K	.2 - 3K	.6 - 11K	.3 - 6K	2 - 48K	4 - 92K	.01 - 200	200
DV2TLVCP	.2 - 3K	.6 - 11K	.3 - 6K	2 - 48K	4 - 92K	.01 - 200	200	.3 - 1K	1 - 3K	.6 - 2K	5 - 16K	9 - 30K	0.3 - 100	18
LVDV-IPCP	.3 - 1K	1 - 3K	.6 - 2K	5 - 16K	9 - 30K	0.3 - 100	18	1 - 32K	5 - 122K	2 - 64K	20 - 512K	39 - 983K	.01 - 250	2.6K
DV3TRVCP	1 - 32K	5 - 122K	2 - 64K	20 - 512K	39 - 983K	.01 - 250	2.6K	1.6 - 32K	6 - 122K	3 - 64K	25 - 512K	49 - 983K	.01 - 200	200
DV2TRVCP	1.6 - 32K	6 - 122K	3 - 64K	25 - 512K	49 - 983K	.01 - 200	200	3 - 10K	12 - 41K	6 - 21K	51 - 170K	98 - 327K	0.3 - 100	18
RVDV-IPCP	3 - 10K	12 - 41K	6 - 21K	51 - 170K	98 - 327K	0.3 - 100	18	2.6 - 65K	10 - 245K	5 - 128K	41 - 1M	78 - 2M	.01 - 250	2.6K
DV3THACP	2.6 - 65K	10 - 245K	5 - 128K	41 - 1M	78 - 2M	.01 - 250	2.6K	3 - 65K	12 - 245K	6 - 128K	51 - 1M	98 - 2M	.01 - 200	200
DV2THACP	3 - 65K	12 - 245K	6 - 128K	51 - 1M	98 - 2M	.01 - 200	200	6.6 - 21K	24 - 81K	12 - 42K	102 - 341K	196 - 655K	0.3 - 100	18
HADV-IPCP	6.6 - 21K	24 - 81K	12 - 42K	102 - 341K	196 - 655K	0.3 - 100	18	10.5 - 261K	39 - 982K	20 - 512K	163 - 4M	314 - 7.8M	.01 - 250	2.6K
DV3THBCP	10.5 - 261K	39 - 982K	20 - 512K	163 - 4M	314 - 7.8M	.01 - 250	2.6K	13 - 261K	49 - 982K	25.6 - 512K	204 - 4M	393 - 7.8M	.01 - 200	200
DV2THBCP	13 - 261K	49 - 982K	25.6 - 512K	204 - 4M	393 - 7.8M	.01 - 200	200	26 - 87K	98 - 327K	51 - 170K	409 - 1M	786 - 2.6M	0.3 - 100	18
HBDV-IPCP	26 - 87K	98 - 327K	51 - 170K	409 - 1M	786 - 2.6M	0.3 - 100	18							

M = 1 million K = 1 thousand cP = Centipoise mPa*s = Millipascal*seconds mL = Milliliter N = RPM e.g. Spindle CPA-40Z 7.50 x 10 (rpm) = 75.0 sec⁻¹
* Dependant upon cone selected.

RheocalcT Software Optional for DV2T and DV3T

GET TOTAL CONTROL OF YOUR INSTRUMENT AND TEST PARAMETERS

Automatically control and collect data with RheocalcT and a dedicated computer. RheocalcT can analyze data, generate multiple plot overlays, print tabular data, run math models and perform other time-saving routines. Up to five comparison data sets can be plotted and saved. Other features include:

- Wizards to guide you through the creation of common tests
- Secure 21CFR features including multiple logins, access levels, digital signatures, and data storage in a password-protected database
- Looping functions for repetitive tasks
- Averaging of collected data by step or whole test
- Math models: Bingham, Casson, Casson NCA/CMA, Power Law, IPC Paste, Herschel-Bulkley, Thix Index

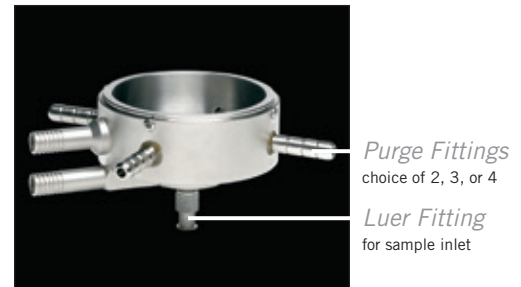

Optional Sample Cup

The Optional Sample Cup has luer and purge fittings for introducing and removing test sample while cup remains attached to instrument

Wingather Software Optional for DV-I Prime

DATA COLLECTION SOFTWARE TO COLLECT, ANALYZE AND RECORD TEST DATA

Wingather software provides an easy way to gather data and plot graphs while creating permanent test records. Data can be saved in the program or exported to Excel.

- Automates data collection to save time
- Reduces operator error
- Math modeling for yield stress calculations, plastic index
- Plot up to four data sets for comparisons

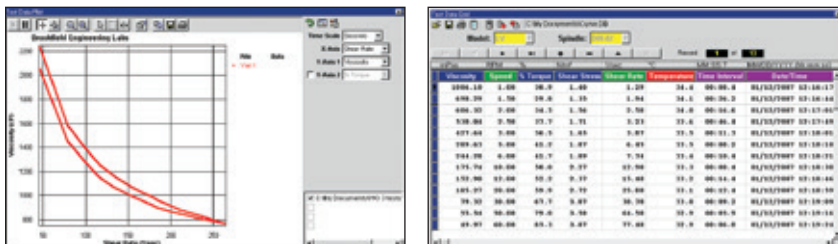

CAP 1000+™ & CAP 2000+™

Cone & Plate Viscometers

Keypad for direct input of test parameters

Cone Spindle is easily removed for cleaning

Easy-to-Use Control Handle for accurate, automatic cone positioning

Designed to handle repetitive testing in production environments with easy setup and cleaning

4-Line Display allows simultaneous viewing of all test parameters

Choice of instruments:
CAP1000+ (single speed)
CAP2000+ (variable speed)

Automatic cone/gap positioning

Small sample size
less than 1 mL

Built-in Peltier Plate for temperature control of sample:
L Series: 5°C — 75°C
H Series: 50°C — 235°C



What's Included?

- Instrument
- Choice of Torque Range:
 - High Torque (ICI Specification): 181,000 dyne • cm
 - Low Torque: 7,970 dyne • cm
- Choice of One Cone Spindle (p42)
- Choice of Temperature Control: L or H

Optional Accessories

- CAP Viscosity Standards (p53)
- Additional Cone Spindle (p46)
- Capcalc32 Software ▶
- Protective Keypad Covers (p51)

CAP1000+

Single speed 750 or 900 rpm instrument, ideal for QC. Optional choice of alternative speed is available upon request. See examples below at 400 rpm and 100 rpm.

CAP2000+

Variable speed 5-1000 rpm instrument ideal for R&D as well as more detailed QC testing. Automated PC control (using optional Capcalc32 software).

MODEL	VISCOSITY RANGE cP(mPa•s)		SPEEDS	
	Min.	Max.	RPM	Number of Increments
CAP 1000+	see chart on (p15)		900/750	2
CAP 2000+			5-1K	995

* Dependant on cone selected.
M = 1 million K = 1 thousand cP = Centipoise mPa•s = Millipascal•seconds

Capcalc32 Software Optional

TURN YOUR CAP2000+ VISCOMETER INTO A MORE POWERFUL RHEOMETER

Capcalc32 allows control of the CAP2000+ Viscometer while providing automatic data capture and graphical display. Automate your CAP 2000+ Viscometer and generate flow curves quickly and easily.

- Controls test parameters with powerful scripting capabilities
- Looping functions for repetitive tasks
- Automates data collection to save time
- Reduces operator error
- Math modeling for yield stress calculations, plastic index
- Plot up to four data sets for comparisons

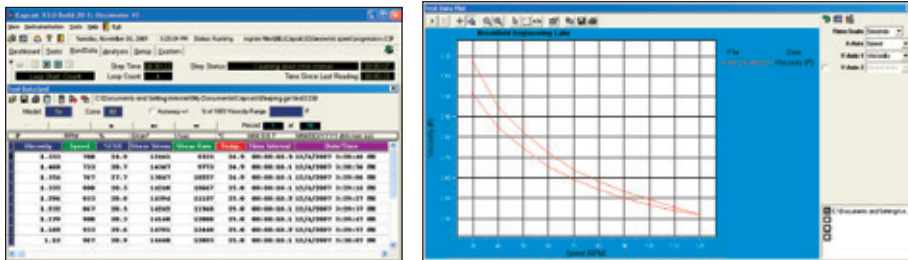

Applications

MEDIUM VISCOSITY

Adhesives (hot melt)	Coatings	Resins
Architectural Coatings	Industrial Coatings	Starches
Autocoats (Hi-performance)	Inks (screen printing)	Surface
Creams	Organisols	UV Coatings
Food Products	Paints	Varnish
Gels	Paper Coatings	
Gums	Plastisols	

HIGH VISCOSITY

Adhesives	Gels	Sealants
Asphalt	Inks (ballpoint, offset, lithographic)	Sheet Molding
Compound		
Chocolate	Molasses	Tars
Composite Polymers	Pastes	Vinyl Esters
Epoxies	Roofing Compounds	

Perfect for Paints & Coatings

Meets Industry Standards:
ASTM D4287, ISO 2884, BS 3900
High Shear Rate Cone & Plate
(10,000 sec⁻¹)

CAP Cone Viscosity Ranges (Poise)

MODEL	Shear Rate (sec ⁻¹): 13.3N Sample Volume: 67µL Cone Spindle: CAP-01	Shear Rate (sec ⁻¹): 13.3N Sample Volume: 39µL Cone Spindle: CAP-02	Shear Rate (sec ⁻¹): 13.3N Sample Volume: 24µL Cone Spindle: CAP-03	Shear Rate (sec ⁻¹): 13.3N Sample Volume: 13.3µL Cone Spindle: CAP-04	Shear Rate (sec ⁻¹): 3.3N Sample Volume: 67µL Cone Spindle: CAP-05	Shear Rate (sec ⁻¹): 3.3N Sample Volume: 39µL Cone Spindle: CAP-06	Shear Rate (sec ⁻¹): 2.0N Sample Volume: 170µL Cone Spindle: CAP-07	Shear Rate (sec ⁻¹): 2.0N Sample Volume: 100µL Cone Spindle: CAP-08	Shear Rate (sec ⁻¹): 2.0N Sample Volume: 170µL Cone Spindle: CAP-10
HIGH TORQUE									
1000+ @750rpm	.25-2.5	.5-5	1-10	2-20	4-40	10-100	N/A	N/A	N/A
1000+ @900rpm	.2-2	.4-4	.8-8	1-16	3-33	8-83	N/A	N/A	N/A
1000+ @400rpm	.375-4.6	.75-9.3	1.5-18.7	3-37.5	6-75	15-187	.78-7.81*	3.13-31.3*	12.5-125*
2000+ @5-1000rpm	.2-375	.4-750	.8-1.5K	1-3K	3-6K	8-15K	.78-625*	3.13-2.5K*	12.5-10K*
LOW TORQUE (for applications requiring low shear rates for low/medium viscosity fluids, an optional low torque 797-7,970 dyne•cm instrument can be ordered)									
1000+ @100rpm†	.2-.81	.2-1.6	.33-3.3	.65-6.5	1.3-13	3.3-33	.13-1.3	.54-5.4	2.2-22
2000+ @5-1000rpm	.2-16	.2-32	.2-66	.2-130	.2-260	.2-660	.2-26	.2-108	.2-440

µL = microliter K = 1 thousand P = poise 1 Pa•s = 10 poise N = RPM e.g. Cone CAP-01 13.3 x 10 (rpm) = 133 sec⁻¹
 *Maximum speed recommended with this spindle is 400 rpm. Viscosity range indicated is for operation at 400 rpm. †Special speed instrument.
 Note: Viscosity ranges shown above are for illustration. The exact range will depend upon instrument configuration.

PVS™ Rheometer

1' x 1' x 2' instrument for portable site-to-site mobility

Robust Motor

capable of speeds up to 1000 rpm

Quick and easy setup

in minutes

Safety Relief Valve

1000psi (high pressure)

Avoids sample boil-off

Couette Geometry

Outside Cylinder Rotates, "Bob" inside remains stationary, generating shear rates up to 1700 sec⁻¹

RTD on the inner cylinder

insures accurate sample temperature measurement

Test to industry standards

Vacuum to high pressure

measurements up to 1,000 psi

Hastelloy C cup and bobs

for operation in severe field environments

Low Shear Rate Viscosity (LSRV)

measurement to .02 sec⁻¹

Fluid Temperature conditions:

from -40°C to +260°C



What's Included?

- Instrument
- Choice of spindle (bob) (p23)
- Sample Cup (p41)
- RheoVision software ▶
- Carrying Case ▶

Optional Accessories

- Viscosity Standards (p52)
 - Additional spindle (bobs) (p23)
 - Computer
 - Temperature Control Bath
 - Thermo Bath (p23)
- Available with triple annulus geometry for increased sensitivity when measuring low viscosity fluids



MODEL	VISCOSITY RANGE cP(mPa•s)		SPEEDS	
	Min.	Max.	RPM	Number of Increments
PVS	.5	36M	.05-1K	10K

* Ranges depend on "Bob" spindle selected.
M = 1 million K = 1 thousand cP = Centipoise mPa•s = Millipascal•seconds

RheoVision® Software Included

FOR AUTOMATION AND CONTROL OF ALL TEST PARAMETERS

Specifically designed for sophisticated rheological analysis, RheoVision makes viscosity measurement under pressurized and temperature controlled conditions an easy task. Powerful scripting language provides simple to complex data collection programs including automatic calculation of yield stress using Bingham, Herschel-Bulkley, and Power Law equations.

- USB and RS232 connectivity
- Multiple PVS units to PC communication controls.
- Enhanced graphing capabilities
- Easy calibration checks with auto-calculation of the torque multiplier and built-in linearity check
- Use of a powerful Microsoft SQL database allows users to
 - Define product, fluids, customer, location and other specific parameters for samples and later search data on these same fields
 - Search tests by parameters and allow data and test parameters to link for easier full profile viewing
- Instantaneous flow curves
- Built in math modeling
- User-friendly ramp wizard for quick API testing
- Seal history tracking feature

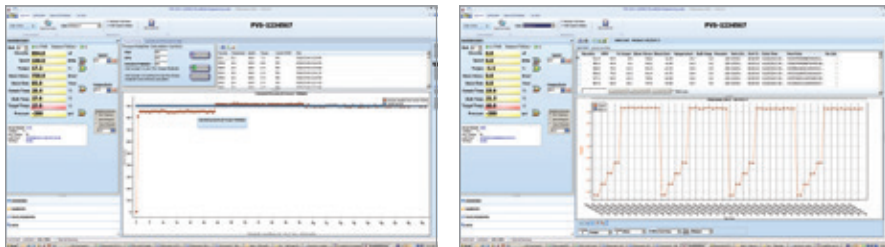

Applications

Fracturing Fluids Drilling Muds Volatile Chemicals
 Petroleum Products Black Liquor

PVS Spindles, Chambers and Rheometer Ranges			
BOB/STATOR SAMPLE CUP	VISCOUSITY RANGE cP(mPa·s)	SHEAR RATE (sec ⁻¹)	SAMPLE VOLUME (mL)*
PVS-B1-D-HC	2-5M	1.70N	23
PVS-B2-D-HC	20-36M	0.38N	40
PVS-B5-D-HC	5-10M	0.85N	30
PVS-TA5B5-D-HC	.5-1M	0.85N	175
CHAMBER			
PVS-30 (standard)	for use with B1, B2 or B5 spindle		
Triple Annulus	for use with PVS - TA5 B5 - D - HC		

*±1mL HC = Hastelloy C M = 1 million N = RPM mL = Milliliter



NEW Thermo Bath option with PID Enhanced Control Capability

for sample heating with small space requirement. Call for details.



Carrying Case

for portability in the field



PVS CHAMBER

PVS SPINDLE

NEW RST Touch™ Series Rheometers

Touch Screen Rheometers for Controlled Rate/Stress Measurement

The RST series of touch screen rheometers represent the best that Brookfield has to offer — instruments that operate both in controlled shear rate (rpm) and controlled shear stress (torque) modes — for sophisticated rheological analysis. With automatic data collection and analysis using optional Rheo3000 software, RST Rheometers offer greater flexibility and more features than other high-end rheometers in their class — at a fraction of the cost.

RST Rheometers have a durable design with rapid bob (spindle) attachment and easy-to-clean surfaces for years of trouble-free operation. Increased measurement capabilities range from simple single-point viscosity tests to comprehensive rheological profiling. Evaluate material behavior from initial yield stress through full flow curve response at variable shear rates to relaxation, recovery and creep.

The RST touch screen series is available in three configurations and all models feature:

- Controlled stress/rate operation to analyze comprehensive flow behavior
- User friendly LCD touch screen with graphical display
- 11 memory slots for structured multi-step test programs
- Auto spindle identity recognition
- Quick connect coupling for easy spindle attachment
- Optional Rheo 3000 Software for PC control and data management
- 21 CFR compliance for controlled user access and data security

A portable version without touch screen capability (Model RS Portable) is also available.

RST Technical Specifications (all models)

Maximum Torque:	100 mNm
Torque Resolution:	0.15 μ Nm
Speed:	0.01 to 1300 rpm
Data Output:	USB, RS232
Display Units:	cP, Pa•s, dynes/cm ² , Pa, °C, °F

Some popular applications include:

ADHESIVES: RST-CPS tests a variety of silicone-based adhesives at temperatures in excess of >200°C. Advantages include small sample volume (< 2mL), rapid temperature equilibrium with Peltier plate, variable shear rate (to 7,800 sec⁻¹) to duplicate conditions for actual adhesive use, quick test time (< 2 min).

ADHESIVE INGREDIENTS: RST-CPS with Peltier control excels at rapid QC measurements at defined shear rates. Optional Peltier plate changes temperature much more quickly than bath/circulator. Test throughput increases dramatically.

BIOMASS: RST-CC with vane spindle in coax chamber measures biomass fluids used for biofuel production. Easily handles suspended solids and evaluates important flow properties by simulating what happens to the material during pumping in production.

CHOCOLATE: RST-CC is instrument of choice for select manufacturers who run 24/7 operations requiring robust, reliable performance. Choice of optional serrated bob (spindle). Conforms to DIN and ISO test methods which quantify yield stress and consistency using Casson analysis. Affordable alternative to higher priced rheometers.

DAIRY: RST-CC with double-gap geometry measures low viscosity (<0.1 Pa•s) dairy products ranging from skim milk to thicker creams.

GYPSUM: RST-SST is popular choice for measurement of joint compound manufactured by the gypsum industry in accordance with ASTM C474. Small footprint, data display in BU units, and robust design make it ideal for lab and production floor use.

PESTICIDES: RST-CC with double-gap geometry measures various low viscosity formulations (0.001 Pa•s) at shear rates up to 5,600 sec⁻¹. Provides reliable capability in a busy QC lab measuring dozens of samples each day.

PHARMACEUTICAL: RST-CPS with open plate design for easy sample placement accommodates a variety of small sample sizes (< 4mL) and rapid temperature control using the Peltier option. Produces quick profiling of flow behavior, including yield stress and creep, important properties for characterizing ointments.

PIGMENT DISPERSIONS: RST-CPS with Peltier is used by a range of industrial markets, including plastics and paints. Handles broad viscosity range from thin formulations (0.025 Pa•s) to non-flowing pastes. Broad shear rate capability simulates both processing of materials (pumping and mixing) and application of material (brushing and spraying).

SAUCES AND SYRUPS: RST-CPS with Peltier replaces traditional hour-long viscosity tests which measure product from a cooking vessel after it cools to room temperature. Peltier option cools sample to 25°C in less than 1 minute, greatly reducing test time.

SLUDGE/SLURRIES/CONCRETE: RST-SST with vane spindle geometry measures diverse mixtures with particulates ranging in concentration up to 70% solids.

RST-CPS Touch™ Rheometer

Cone/Plate & Plate/Plate Systems for small samples and wide shear rate ranges

Controlled shear stress/shear rate operation makes it easy to study material behavior from initial yield to flow curve response

User-friendly Touch Screen and graphical display for stand-alone operation

Quick Connect Coupling System for easy spindle attachment

Very Small Sample Size permits rapid test set up and clean up

Spindle Barcode for auto spindle recognition



Optional Rheo3000 Software allows for PC control and data acquisition/analysis of multiple test files

Automatic or Manual Gap Setting for quick and easy gap setting

Rapid Temperature Control of plate with Peltier option for quick profiling of viscosity vs. temperature

What's Included?

Instrument (with choice of water bath, Peltier or electric temperature control for sample plate)
Convenience Package (USB Flash Drive, Stylus, Cleaning Cloth, Screen Protector)

Optional Accessories

Choice of cone or plate spindle geometries at least one is required (p47)
Rheo3000 Software
Viscosity Standards (p53)
Water Baths (p33-35)
Solvent Trap
Thermal Barrier
KE Cooling Device



Choice of cone spindles and plate spindles accommodates all sample types. Plate spindles are used for highly-filled or very viscous samples.



Thermal Barrier reduces the effects of heat transfer to the environment. Two part chamber provides thermal isolation of the measurement zone.



The optional KE cooling device is required to cool viscometer bearings when testing with temperatures above 70°C.

MODEL	VISCOSITY RANGE (Pa•s)		SPEEDS
	Min.	Max.	RPM
RST-CPS Cone/Plate	0.0006	814K	0.01-1.3K
RST-CPS Plate/Plate	0.002	2.49M	0.01-1.3K

See page 47 for individual spindle (bob) ranges K = 1 thousand M = 1 million 1 Pa•s = 1000 cP (centipoise)

Temperature Control Options†		
MODEL	Description	Temperature
RST-CPS-FH	Bath	-20° to 200°C
RST-CPS-PA	Peltier Air	20° to 180°C*
RST-CPS-PO	Peltier Oil	0° to 180°C*
RST-CPS-EH	Electric	40° to 250°C

† Higher temperatures available on request. * 75mm plates cannot be used with Peltier systems. See page 47 for spindle ranges and sample volumes.

RST-CC Touch™ Rheometer

Coaxial Cylinder DIN Geometries for single point QC or full rheological profiling

Spindle Barcode
for auto spindle recognition

Controlled shear stress/shear rate
operation makes it easy to study material behavior from initial yield to flow curve response

Optional Rheo3000 Software
allows for PC control and data acquisition/analysis of multiple test files

Quick Connect Coupling
for easy bob (spindle) attachment

Rugged Design
permits use on production floor

Small sample size
facilitates rapid temperature control during testing

Temperature Control from -20°C to 180°C
Choice of
- Direct immersion in bath
- External circulation using the FTKY3 Water Jacket

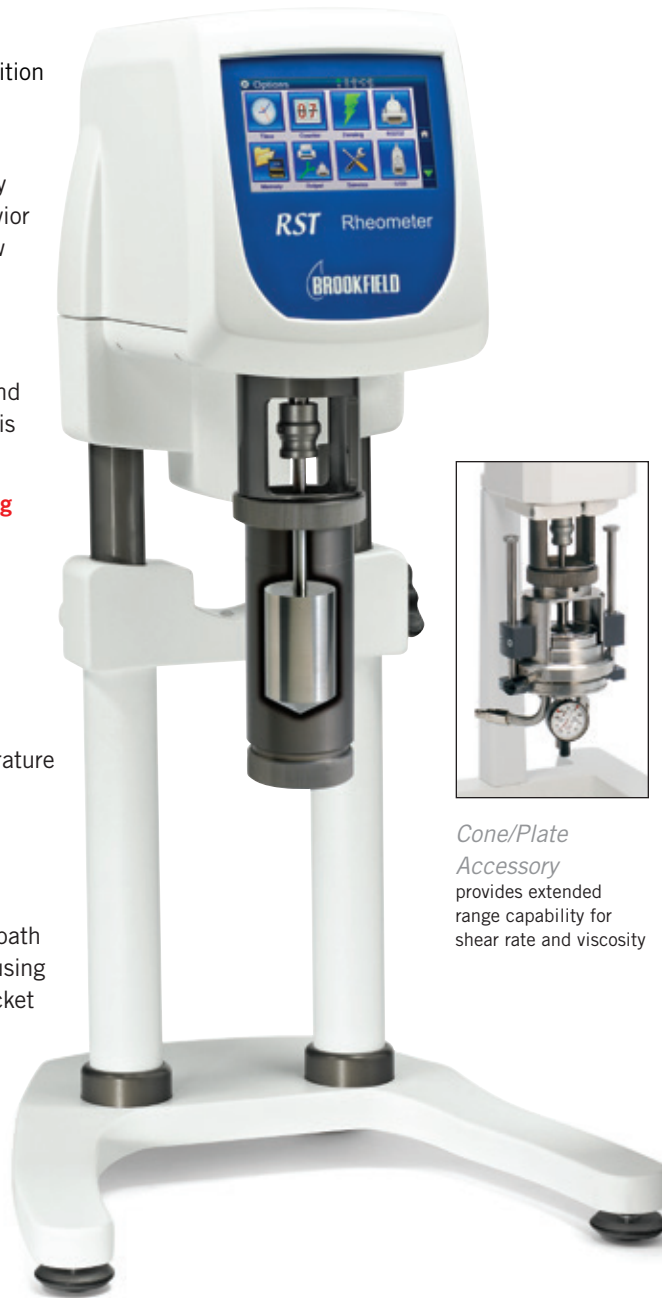

Cone/Plate Accessory
provides extended range capability for shear rate and viscosity

What's Included?

Instrument with stand and adjustable height control with base
Convenience Package (USB Flash Drive, Stylus, Cleaning Cloth, Screen Protector)

Optional Accessories

- Choice of Coaxial Cylinder Bob (spindle) and Chamber at least one bob and chamber is required (p47)
- FTKY3 Water Jacket for Temperature Control
- Rheo3000 Software (p29)
- Viscosity Standards (p53)
- Cone/Plate Accessory (p27)
- KE Cooling Device (required for temperatures over 70°C)
- PT-E Immersion Temperature Sensor
- Disposable Chambers

Water Jacket



Coaxial Cylinder Spindles



Double Gap Coaxial Cylinder for very low viscosity materials

MODEL	VISCOSITY RANGE (Pa•s)		SPEEDS
	Min.	Max.	RPM
RST-CC Coaxial Cylinder	.00005	5.41M	0.01-1.3K

See page 47 for individual bob/spindle ranges K = 1 thousand M = 1 million 1 Pa•s = 1000 cP (centipoise)

RST-SST Touch™ Rheometer

Soft Solids Tester for pastes, slurries and materials with particulates

Spindle Barcode

for auto spindle recognition

Measured Values

- Yield Stress
- Shear Modulus
- Recovery
- Creep

Optional Rheo3000 Software

allows for PC control and data acquisition/analysis of multiple test files

Quantifies meaningful properties

like stiffness, wobbliness, sloppiness, consistency and texture

Capable of measurements in BU units

for viscous materials such as joint compound

Vane Spindle Geometry

- Quick-Connect coupling
- Rapid spindle insertion without compromising sample structure
- Quick and easy test method

Coaxial Cylinders

can also be used for complete flow curve analysis



What's Included?

Instrument with base plate for sample placement and adjustable height control for rheometer head

Convenience Package (USB Flash Drive, Stylus, Cleaning Cloth, Screen Protector)

Optional Accessories

Choice of Spindle Geometries at least one is required:

- Vane (spindle)
- Coaxial Cylinder Bob (spindle) & Chamber
- Rheo3000 Software (p29)
- Viscosity Standards (p53)
- Cone/Plate Accessory (p27)
- Thermosel System (p36-37)
- PT-E Immersion Temperature Sensor



Choice of several vane spindle options



RSS-90Y Spindle for BU measurements on joint compound and similar materials



Cone/Plate Accessory provides extended range capability for shear rate and viscosity

SHEAR STRESS (Pa)

MODEL	Min.	Max.
RST-SST Soft Solids Tester	0.2	218K

See pg. 47 for individual bob and vane spindle ranges K = 1 thousand Pa = Pascal

RS Plus™ Portable Rheometer

...portable measurements in the lab or in the field

Our Lowest Cost Portable Rheometer

provides more capability for much less cost than others in its class.

Dual Modes of Operation

- Controlled Stress (when used with a PC)
- Controlled Rate

Displayed Information:

- Viscosity
- Temperature (with optional PT-E sensor)
- Torque
- Shear Rate
- Shear Stress

Quick Connect Coupling

for easy bob (spindle) attachment



What's Included?

- Instrument
- Carrying Case
- Laboratory Stand
- Battery Charger

Optional Accessories

Choice of Spindle Geometries

at least one is required: (p47)

- Coaxial Cylinder Bob (spindle) & Chamber
- Vane Spindle

Disposable Chambers

Rheo3000 Software (p29)

Viscosity Standard Fluids for Calibration

FTK Water Jacket for Temperature Control

Circulating Temperature Bath

PT-E Immersion Temperature Sensor



Cone/Plate Accessory
provides extended range
capability for shear rate
and viscosity

MODEL	VISCOSITY RANGE (Pa•s)		SPEEDS
	Min.	Max.	RPM
RS Portable	.001	80K	0.7-800

See page 47 for individual spindle ranges K = 1 thousand 1 Pa•s = 1000 cP (centipoise)

Rheo3000 Software

for quick and comprehensive data analysis capabilities with RST series Rheometers

Enhance your productivity

VIA PC CONTROL WHEN CHARACTERIZING MATERIAL RHEOLOGY

Your PC can do the detailed data collection and analysis work for you. Rheo3000 allows you to program the RST Rheometer and control shear stress or shear rate. Data is saved in a SQL database for easy access by multiple users on a network. Use multiple step test programs for complete characterization of material flow behavior: viscoelastic modulus, yield stress, viscosity flow curve, creep behavior, recovery.

In addition, Rheo3000 provides automated analysis of fluid behavior against user-defined control limit values, resulting in better quality control. Mathematical data processing models included are: Newton, Bingham, Casson, Ostwald, Steiger-Ory, and Herschel-Bulkley. Helpful features include:

- 21 CFR compliance option for controlled user access and data security
- Active clock on screen shows test progress to completion
- Export reports in pdf format; choose parameters of interest, discard others

PC Requirements

1.5 GHz Processor
1 GB System Memory
2.5 GB Hard Drive
VGA Graphics Adapter
1 USB/serial port (2 required for external temperature controller)

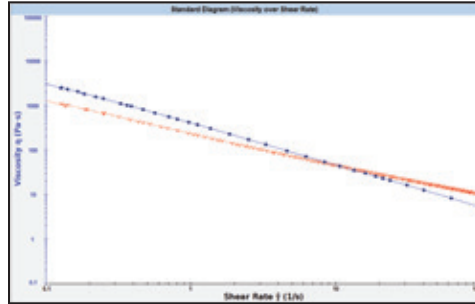

Viscosity Flow Curve: controlled shear stress ramp produces viscosity vs. shear rate graph for two pseudoplastic materials.

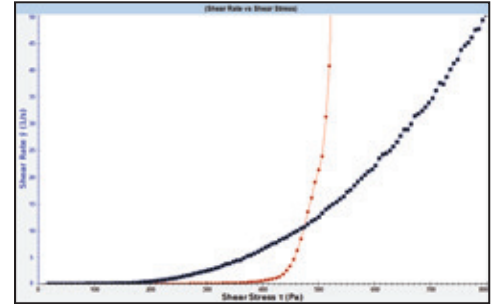

Yield Stress Determination: shear stress ramp from 0 to 800 Pa over 2 minutes shows yield stress values of 200 and 400 Pa for two materials.

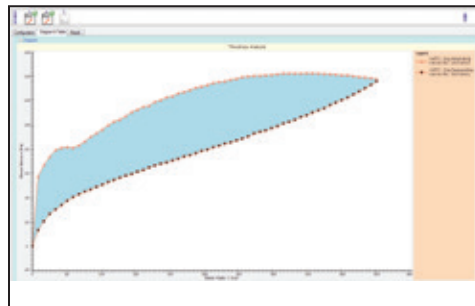

Thixotropy Analysis: Up/down shear rate ramp produces two shear stress vs. shear rate curves; thixotropy calculation is 20977 Pa/s (the area between the curves).

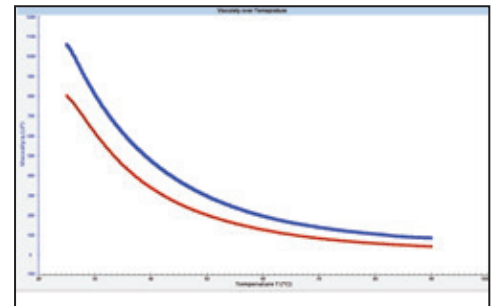

Temperature Profile: Viscosity is measured at constant shear rate of 250 1/s while temperature increases from 25°C to 90°C using RST Cone Plate Rheometer.

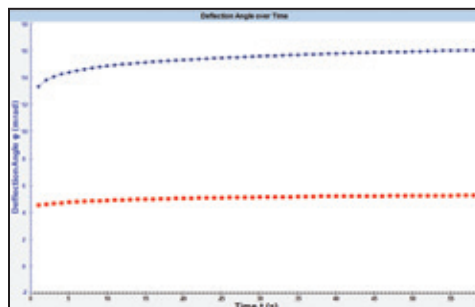

Creep Behavior: Material flow under constant stress is measured by detecting angular rotation of spindle.

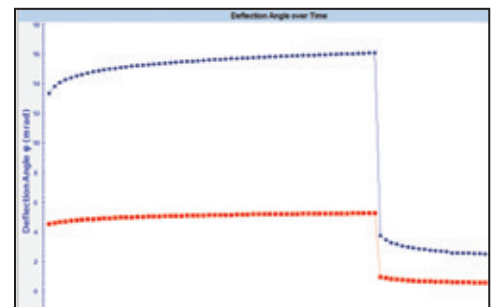

Recovery: Elastic property of material is characterized by spindle relaxation (backward rotation) after constant stress is removed.

YR-1™ Yield Stress Rheometer

a low-cost QC tool to enhance material characterization

Displayed Information:

- Yield Stress (Pa or dynes/cm²)
- % Torque

EZ-Yield Software included

for automated data collection on a PC

Temperature Probe included

(not shown)

Vane Spindle Geometry

works with thin to highly viscous materials

(Does not disturb sample during spindle insertion)

Choice of Spindle Sizes

to fit any sample container

Ideal for QC

User-friendly Keypad

and display for stand-alone operation

Simple to use

Excellent repeatability

Affordable

Ideal for low to high yield testing

of a variety of applications such as foods, personal care, pharmaceutical and adhesives



What's Included?

- Instrument
- V-72 & V-73 Vane Spindles (p43 & 48)
- EZ-Yield Software
- Lab Stand (Model S) (p50)
- Carrying Case

Optional Accessories

- V-71, V-74 & V-75 Vane Spindles (p43 & 48)
- RTD Temperature Probe
- Viscosity Standards (p52)
- Temperature Bath (p33-35)
- Protective Keypad Covers (p51)
- Quick Action Lab Stand (p50)

Vane Spindle Ranges

SPINDLE	TORQUE RANGE	SHEAR STRESS RANGE (Pa)
V-71	1/4RV	.125-1.25
V-72	1/4RV	.5-5
V-73	1/4RV	2.5-25
V-74	1/4RV	25-250
V-75	1/4RV	10-100
V-71	RV	.5-5
V-72	RV	2-20
V-73	RV	10-100
V-74	RV	100-1K
V-75	RV	40-400
V-71	HA	1-10
V-72	HA	4-40
V-73	HA	20-200
V-74	HA	200-2K
V-75	HA	80-800
V-71	HB	4-40
V-72	HB	16-160
V-73	HB	80-800
V-74	HB	800-8K
V-75	HB	320-3.2K

Note:

1. 1 Pa = 10 dyne/cm²

2. Torques higher than HB require use of Model DV-III Ultra (p20-21)

M = 1 million K = 1 thousand Pa = Pascal

cP = Centipoise mPa*s = Millipascal*seconds

KU-2™ Viscometer

for Paints, Coatings, and Inks

ASTM D562 Compatible
(industry specification)

Easy to use
no weights, simplifies an established test procedure

LED Display Info:

- Krebs Units
- Gram Units (Weight)
- Centipoise*

Select Krebs or Grams or Centipoise

Lock-In Test Results
with Hold Switch

Accuracy: ±1.0% of range

Repeatability: ±0.5%

Standard Krebs Spindle

Measurement range:
40 to 141 KU, 32 to 1099 gm,
and 27 to 5274 cP*

Printer Connection
for automatic test documentation

Adapter provided
for 1/2 Pint, Pint,
& Quart Containers



What's Included?

- Instrument
- Krebs-type Spindle (p48)
- Communications Port for Printer
- Adapter for Quart, Pint and Half-Pint Cans†

Optional Accessories

- Air Purge
- Paste Spindle (p48)

Applications

- Paints
- Coatings
- Adhesives
- Inks
- Pastes

*Centipoise values based on the conversion from Krebs Units as defined in the ASTM D562.

†Adapters which accommodate metric size cans are available for an additional fee — contact Brookfield to discuss your requirements

BF35™ Viscometer

measures viscosity of oil drilling and fracturing fluids at atmospheric pressure in both field and laboratory settings

Easy speed changes
with convenient
control knob

Shear Stress Values Displayed
on easy-to-read lighted magnified dial

Maintains a constant shear rate
under varying input power and
drilling fluid conditions. Provides
drilling fluid engineers with an
accurate and versatile tool.

**Conventional oilfield rotor,
bob and torsion spring**
maintain rheology history
and reproducibility between
instruments and laboratories

Sample Cup

Adjustable table height
to accommodate a variety of
beaker/containment sizes

Specifications/Features

Motor Speeds:	8 fixed (3, 6, 30, 60, 100, 200, 300, 600)
Speed Accuracy:	0.001 (rpm)
Readout:	Direct dial with light
Heat Cup:	Stainless steel, 150 Watt, 190°F (88°C) maximum recommended temperature
Geometry:	True Couette Coaxial Cylinder
Power:	97-250 VAC, 50/60 Hz (12 volt operation requires special cable)
Carrying Case	Included



Temperature Control with Brookfield Baths

NEW SERIES OF TEMPERATURE BATH SYSTEMS combine state-of-the-art controller displays with high performance circulating baths to give accurate viscosity test results

All controllers are swivel-mounted so that user can adjust position for optimum viewing angle



AP Series Controllers

- Color touch-screen interface
- Standalone programmable or PC control with RheocalcT software
- Variable-speed pump
- Max. temperature up to 200°C
- Multiple languages (English, French, German, Spanish, Chinese available)
- Built-in help menu



SD Series Controllers

- Best value
- Programmable with PC control using RheocalcT software
- Quick scroll to set temperature in standalone mode
- 2-speed pump
- Maximum temperature up to 170°C



MX Series Controllers

- Economical
- Large character display
- Single-speed pump
- Maximum temperature up to 135°C

Step 1: Choosing the controller

CHOOSE THE ONE THAT BEST SUITS YOUR APPLICATION

- Choose the controller by considering factors such as the need for PC control using RheocalcT with DV2T or DV3T, ease of use, pump speed, and foreign language choices (AP series controller only).

Temperature Baths Features

MODEL	Temperature Range Low	Temperature Range High	Controller	Cooling	Temperature Stability†	Digital Readout/Accuracy	Reservoir Capacity	Pump Speed	Maximum Flow Rate	Internal Work Area DMMH (inches)	Overall Dimensions DMMH (inches)	Weight (Gross)
TC-650AP	-20°C	+200°C	AP	Refrigerated	0.01°C	Touch Screen	7.0 liters	Variable	16 LPM	6.18 x 5.59 x 5.0	21.3 x 8.7 x 24.3	90 lbs
TC-650SD	-20°C	+170°C	SD	Refrigerated	0.04°C	LCD/Scroll Touch	7.0 liters	2-speed	11 LPM	6.18 x 5.59 x 5.0	21.3 x 8.7 x 24.3	90 lbs
TC-650MX	-20°C	+135°C	MX	Refrigerated	0.07°C	LCD	7.0 liters	1-speed	12 LPM	6.18 x 5.59 x 5.0	21.3 x 8.7 x 25.4	84 lbs
TC-550AP	-20°C	+200°C	AP	Refrigerated	0.01°C	Touch Screen	7.0 liters	Variable	16 LPM	6.18 x 5.59 x 5.0	23.2 x 16.2 x 16.2	90 lbs
TC-550SD	-20°C	+170°C	SD	Refrigerated	0.04°C	LCD/Scroll Touch	7.0 liters	2-speed	11 LPM	6.18 x 5.59 x 5.0	23.2 x 16.2 x 16.2	90 lbs
TC-550MX	-20°C	+135°C	MX	Refrigerated	0.07°C	LCD	7.0 liters	1-speed	12 LPM	6.18 x 5.59 x 5.0	23.2 x 16.2 x 17.3	84 lbs
TC-250AP*	ambient +10°C†	+150°C	AP	Tap Water	0.01°C	Touch Screen	10.0 liters	Variable	16 LPM	5.0 x 11.0 x 6.0	13.9 x 13.5 x 14.9	45 lbs
TC-250SD*	ambient +10°C†	+150°C	SD	Tap Water	0.04°C	LCD/Scroll Touch	10.0 liters	2-speed	11 LPM	5.0 x 11.0 x 6.0	13.9 x 13.5 x 14.9	45 lbs
TC-250MX*	ambient +10°C†	+135°C	MX	Tap Water	0.07°C	LCD	10.0 liters	1-speed	12 LPM	5.0 x 11.0 x 6.0	13.9 x 13.5 x 16.0	39 lbs
TC-150AP*	ambient +10°C†	+150°C	AP	Tap Water	0.01°C	Touch Screen	6.0 liters	Variable	16 LPM	4.5 x 4.0 x 6.0	13.4 x 8.1 x 14.9	26 lbs
TC-150SD*	ambient +10°C†	+150°C	SD	Tap Water	0.04°C	LCD/Scroll Touch	6.0 liters	2-speed	11 LPM	4.5 x 4.0 x 6.0	13.4 x 8.1 x 14.9	26 lbs
TC-150MX*	ambient +10°C†	+135°C	MX	Tap Water	0.07°C	LCD	6.0 liters	1-speed	12 LPM	4.5 x 4.0 x 6.0	13.4 x 8.1 x 16.0	20 lbs
TC-351	-20°C	N/A	N/A	N/A	N/A	N/A	N/A	N/A	N/A	N/A	14.0 x 14.0 x 14.0	72 lbs

* For use at lower temperatures, use the built-in tap water cooling, or use model TC-351 Cooler for control to -20°C.

† Low temperature limit 10°C above ambient unless external cooling is used.

‡ Temperature stability may vary depending on bath volume, surface area, insulation and type of fluid

N/A - Not Applicable
FOR OPERATING TEMPERATURES HIGHER THAN 80°C,
PLEASE CONTACT BROOKFIELD FOR BATH FLUID RECOMMENDATIONS.

Step 2: Choosing the bath

CHOOSE THE CIRCULATING BATH THAT MEETS YOUR NEEDS

Determine the type of circulating bath needed by considering temperature range, cooling requirements, reservoir capacity, flow speeds and built-in drains (Models TC-550 and TC-650). Consult the chart on page 33 for specifications.

TC-550

PC control capable
with RheocalcT software

Circulating Water Bath Refrigerated

Most popular choice with widest temperature control capability

7-liter reservoir capacity

Configured to measure viscosity directly in the bath or circulate to external water-jacketed devices**

Accommodates one 600 mL beaker

Provides stand-alone operation with no tap water required and easy control of set-point

Available with MX, SD or AP Controllers

Automated sample temperature control available with SD and AP Controllers

AP Controller shown



TC-650

PC control capable
with RheocalcT software

Circulating Water Bath Refrigerated

Compact — small “footprint” on your lab bench or can be placed underneath lab bench

7-liter reservoir capacity

Specifically designed for circulating to external water-jacketed devices**

Accommodates one 600 mL beaker

Provides stand-alone operation with no tap water required and easy control of set-point

Available with MX, SD or AP Controllers

Automated sample temperature control available with SD and AP Controllers

AP Controller shown



*Provided tap water temperature is 15°C or lower

**All baths can be used with Brookfield water jacketed devices; Wells-Brookfield Cone/Plate Viscometer, R/S-CC and R/S-CPS Rheometers and Small Sample Adapter, Ultra-Low Adapter and DIN Adapter accessories

TC-150

Circulating Water Bath Non-Refrigerated

Compact – smallest “footprint” available
6-liter reservoir capacity

Removable deck lid accommodates
one 600 mL beaker to measure viscosity
directly in the bath

Tap water cooling coil for
temperature control at 25°C*

Built-in circulator pump for use
with external water-jacketed devices**

Available with MX, SD or AP Controller

MX Controller
shown



Water Bath Accessories

Algicide 8 oz.

TC-Fluid 1A available in USA only
Keeps circulator baths clean,
odor free and resists black algae

50/50 Premix
Ethylene Glycol 1 gal.

TC-Fluid 2 -20°C to +100°C

Ethylene glycol 1:1 solution, ready to use

High Temperature Fluid 1 gal.

TC-Fluid 3 +50°C to +150°C

TC-Fluid 4 +100°C to +200°C

PVS-152 +25°C to +200°C

These heat transfer fluids provide superior
thermal stability

Low Temperature Fluid 1 gal.

TC-Fluid 5 -50°C to +58°C

Excellent low temperature performance

Little or no evaporation

Bath Cleaner 8 oz.

TC-Fluid 6A

Removes rust and mineral deposits

Concentrated liquid

18” Lab Stand Rod

VS-CRA-18S

Designed for increasing viscometer height
when measuring in a TC-150, TC-250 or
TC-550 Bath

TC-250

PC control capable
with RheocalcT software

Circulating Water Bath Non-Refrigerated

Largest work area available
for conditioning multiple samples
directly in the bath

10-liter reservoir capacity

Accommodates 600 mL and
1000 mL beakers (cover is
removable for large sample
container requirements)

Built-in tap water cooling coil
for temperature control at 25°C*

Built-in circulator pump for use
with external water-jacket devices**

Available with MX, SD or AP Controller

SD Controller
shown



TC-351

Cooler (not shown) for use with TC-150 & TC-250 Circulating Baths

Eliminates tap water requirements on non-refrigerated baths

Increases lower range of most baths to -20°C



Accessories

Additional benches for elevating the
position of beakers, metal lids for
anchoring beakers, hoses, and deck lid
covers are available. Contact us for details.

Step 3: Comparing bath features

Once you've familiarized yourself with the Brookfield Circulating Water Bath Series
you can easily compare models to find the bath that best suits your requirements.
Consult the chart on page 33 for all TC Series Model specifications.

Thermosel®

for Elevated Temperature Testing



Compatible with standard Brookfield Viscometers and DV3T Rheometers
 Note: requires optional cable DVP-141

Provides control of sample temperature up to +300°C

EZ-Lock Option
 Thermosel is now available with special EZ-Lock spindle coupling for use on standard Brookfield Viscometers/Rheometers already equipped with the EZ-Lock feature

Temperature Ramping between set points is possible if used with RheocalcT (DV3T & DV2T) Software
 Note: Requires optional cable HT-106

Thermo Container (Heating Chamber)



Computer Controlled when used with DV2T or DV3T and RheocalcT Software (HT-106 cable required)

Programmable Temperature Controller offers single set point or up to 10 programmable set points.

Direct Temperature Control Possible with DV2T/DV3T Rheometer (p20)

What's Included?

- Choice of one SC4 Spindle
Specify when ordering
- Alignment Bracket
- Thermo Container with safety guard and insulating cap
- 1 Removable Sample Chamber (p47)
- 5 Disposable Sample Chambers (p47)
Order additional chambers in quantities of 100, HT-2DB-100
- 18" Lab Stand Rod (p35)
- Extracting Tools
- Temperature Controller with an RTD probe

Applications

Hot Melts	Asphalt
Wax	Polymers

The difficulty with viscosity measurements of hot melts and liquids at elevated temperatures has been in maintaining accurate temperature control that is consistent from sample to sample so that meaningful data could be obtained.

The Brookfield Thermosel solves this problem by providing a stable, precisely controlled sample environment. This, together with the inherent accuracy of the Brookfield Viscometers, is fundamental to the Thermosel System, which produces viscosity measurements that are not only accurate but entirely reproducible.

Several factors contribute to the stable environment:

- Non-fluctuating temperature control
- Small sample volume and insulated sample chamber which reduces temperature gradients within the sample
- The rotating spindle, which acts as a built-in stirring device
- The test procedure is quite straightforward. Once familiar with the system, unskilled operators can easily produce accurate, reproducible data.

Thermosel Viscosity Ranges cP(mPa*s)

SPINDLE SAMPLE VOLUME SHEAR RATE (sec ⁻¹)† MODEL	SC4-18 8mL 1.32N	SC4-31 10mL .34N	SC4-34 9.5mL .28N	SC4-21 8mL .93N	SC4-27* 10.5mL .34N	SC4-28 11.5mL .28N	SC4-29 13mL .25N	HT-DIN-81** 7mL 1.29N
DV3TLV	1.2-30K	12-300K	24-600K	Not applicable for historical reasons. However, it is possible to use the above spindles with any of these instruments.				1.0-10K
DV2TLV	1.5-30K	15-300K	30-600K					3.4-10K
LVDV-IP	3-10K	30-100K	60-200K	Digital Viscometers/Rheometers will automatically calculate viscosity. Please contact Brookfield or an authorized dealer if you require information on viscosity range.				3.4-10K
LVDVE	3-10K	30-100K	60-200K					3.4-10K
LVT	5-10K	50-100K	100-200K					5.7-10K
DV3TRV				20-500K	100-2.5M	200-5M	400-10M	14.6-10K
DV2TRV				25-500K	125-2.5M	250-5M	500-10M	36.5-10K
RVDV-IP				50-170K	250-830K	500-1.7M	1K-3.3M	36.5-10K
RVDVE	Not applicable for historical reasons.			50-170K	250-830K	500-1.7M	1K-3.3M	36.5-10K
RVT	However, it is possible to use the above spindles with any of these instruments.			50-100K	250-500K	500-1M	1K-2M	36.5-10K
DV3THA				40-1M	200-5M	400-10M	800-20M	29.2-10K
DV2THA	Digital Viscometers/Rheometers will automatically calculate viscosity. Please contact Brookfield or an authorized dealer if you require information on viscosity range.			50-1M	250-5M	500-10M	1K-20M	73.0-10K
HADV-IP				100-300K	500-1.7M	1K-3.3M	2K-6.7M	73.0-10K
HADVE				100-300K	500-1.7M	1K-3.3M	2K-6.7M	73.0-10K
HAT				100-200K	500-1M	1K-2M	2K-4M	73.0-10K
DV3THB				160-4M	800-20M	1.6K-40M	3.2K-80M	116.8-10K
DV2THB				200-4M	1K-20M	2K-40M	4K-80M	292.0-10K
HBDV-IP				400-1.3M	2K-6.7M	4K-13.3M	8K-26.7M	292.0-10K
HBDVE				400-1.3M	2K-6.7M	4K-13.3M	8K-26.7M	292.0-10K
HBT				400-800K	2K-4M	4K-8M	8K-16M	292.0-10K

M = 1 million K = 1 thousand N = RPM † Spindle SC4-18 1.32 x 10 (rpm) = 13.2 sec⁻¹ cP = Centipoise mPa*s = milliPascal*seconds

*Optional disposable SC4-27D spindle is available in quantities of 100, Part No. SC4-27D-100. Requires special chuck/closer, Part No. SC4-DSY, for attachment to viscometer.

**The 81 spindle, Part No. HT-DIN-81, works in an HT-2 or HT-2DB chamber.

Additional Information



Alignment Bracket ensures concentricity of spindle and sample chamber.



Other components supplied include sample chamber holder, RTD probe, insulating cap, coupling link, coupling nut and choice of SC4 spindle.



Extracting Tool enables the sample chamber to be handled easily and safely.



Option: Disposable Sample Chamber with Optional Disposable Spindle SC4-27D* is ideal for asphalts or any difficult-to-clean material.

Order disposable SC4-27D spindle in quantities of 100, Part No. SC4-27D-100.

Requires special chuck/closer, Part No. SC4-DSY, for attachment to viscometer.

Order disposable HT-2DB chambers in quantities of 100, Part No. HT-2DB-100.

Small Sample Adapter™

for rheological evaluation where sample volume is limited

Standard Sample Chamber with embedded temperature probe provides direct temperature measurement of sample

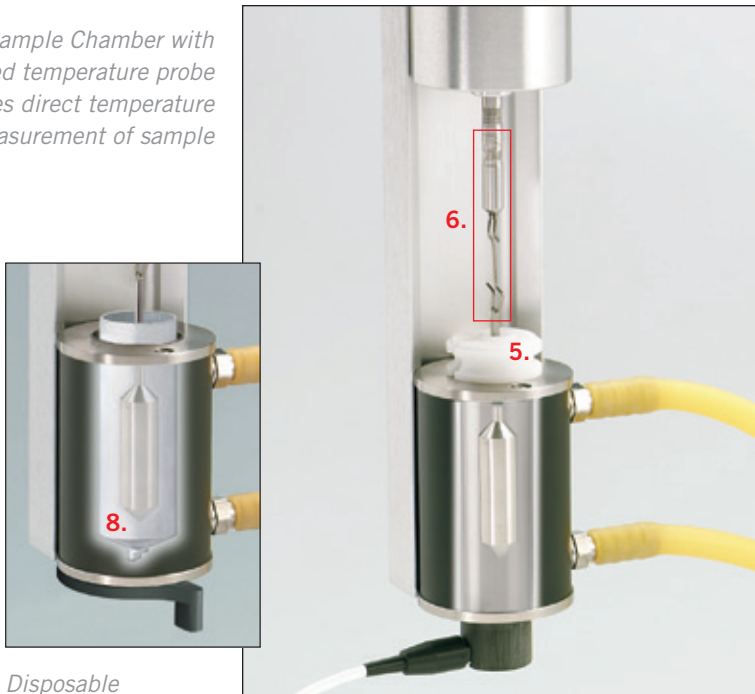

Disposable Sample Chamber (Requires SSA-DCU Water Jacket)

Complete system shows the DV2T Viscometer and Small Sample Adapter with Circulating Water Bath for temperature control.



12.

What's Included?

1. Water Jacket
 2. Locating Channel Assembly
 3. Choice of one SC4 Spindle*
 4. Choice of one SC4 Sample Chamber*
 5. Insulating Cap
 6. Extension Link with Coupling Nut
- Storage Case (not shown)

*Specify when ordering

Optional Accessories

7. Embedded RTD temperature Probe in Chamber
 8. SC4-13RD-100 (100/box) Disposable Sample Chambers (p48) Requires special water jacket
 9. SC4-27D-100 (100/box) Disposable Spindles (p48)
 10. SSA-DCU Special Water Jacket and SC4-13RD Disposable Chambers (100/box)
 11. SSA27D-13RD-100 Includes SSA-DCU items (above) plus SC4-27D Disposable Spindles (100/box)
 12. Temperature Bath (p33-35)
 13. EZ-Lock Spindle Coupling (p50)
- For more info on Small Sample Adapter Accessory Kits visit our website.

The Small Sample Adapter provides a defined geometry system for accurate viscosity measurements at precise shear rates. Consisting of a cylindrical sample chamber and spindle, the Small Sample Adapter is designed to measure small sample volumes of 2 to 16 mL, and easily attaches to all standard Brookfield Viscometers/Rheometers.

Small Sample Adapter Viscosity Ranges cP(mPa•s)

MODEL	Spindle: SC4-18 Sample Chamber* SC4-13R(P) Sample Volume: 6.7mL Shear Rate (sec ⁻¹): 1.32N	Spindle: SC4-37 Sample Chamber* SC4-13R(P) Sample Volume: 9.0mL Shear Rate (sec ⁻¹): .34N	Spindle: SC4-34 Sample Chamber* SC4-13R(P) Sample Volume: 9.9mL Shear Rate (sec ⁻¹): .28N	Spindle: SC4-16 Sample Chamber* SC4-8R(P) Sample Volume: 4.2mL Shear Rate (sec ⁻¹): .28N	Spindle: SC4-23Z (316 s/s only) Sample Chamber* SC4-13R(P) Sample Volume: 16.1mL Shear Rate (sec ⁻¹): .22N	Spindle: SC4-21 Sample Chamber* SC4-13R(P) Sample Volume: 7.1mL Shear Rate (sec ⁻¹): .83N	Spindle: SC4-27(D) Sample Chamber* SC4-13R(P) Sample Volume: 10.4mL Shear Rate (sec ⁻¹): .34N	Spindle: SC4-15 Sample Chamber* SC4-7R(P) Sample Volume: 3.8mL Shear Rate (sec ⁻¹): .48N	Spindle: SC4-28 Sample Chamber* SC4-13R(P) Sample Volume: 11.0mL Shear Rate (sec ⁻¹): .28N	Spindle: SC4-29 Sample Chamber* SC4-13R(P) Sample Volume: 13.5mL Shear Rate (sec ⁻¹): .23N	Spindle: SC4-14 Sample Chamber* SC4-8R(P) Sample Volume: 2.1mL Shear Rate (sec ⁻¹): .40N	
DV3TLV	1.2-30K	12-300K	24-600K	48-1.2M	192-4.8M	Not applicable for historical reasons. However, it is possible						
DV2TLV	1.5-30K	15-300K	30-600K	60-1.2M	240-4.8M	to use the above spindles with any of these instruments.						
LVDV-IP	3-10K	30-100K	60-200K	120-400K	800-1.6M	Digital Viscometers/Rheometers will automatically calculate						
LVDVE	3-10K	30-100K	60-200K	120-400K	800-1.6M	viscosity. Please contact Brookfield or an authorized dealer						
LVT	5-10K	50-100K	100-200K	200-400K	800-1.6M	if you require information on viscosity range.						
DV3TRV						20-500K	100-2.5M	200-5M	200-5M	400-10M	500-12.5M	
DV2TRV						25-500K	125-2.5M	250-5M	250-5M	500-10M	625-12.5M	
RVDV-IP						50-170K	250-830K	500-1.7M	500-1.7M	1K-3.3M	1.25K-4.2M	
RVDVE		Not applicable for historical reasons.					50-170K	250-830K	500-1.7M	500-1.7M	1K-3.3M	1.25K-4.2M
RVT		However, it is possible to use the above					50-100K	250-500K	500-1M	500-1M	1K-2M	1.25K-2.5M
DV3THA		spindles with any of these instruments.					40-1M	200-5M	400-10M	400-10M	800-20M	1K-25M
DV2THA		Digital Viscometers/Rheometers will					50-1M	250-5M	500-10M	500-10M	1K-20M	1.25K-25M
HADV-IP		automatically calculate viscosity. Please					100-300K	500-1.7M	1K-3.3M	1K-3.3M	2K-6.7M	2.5K-8.3M
HADVE		contact Brookfield or an authorized dealer if					100-300K	500-1.7M	1K-3.3M	1K-3.3M	2K-6.7M	2.5K-8.3M
HAT		you require information on viscosity range.					100-200K	500-1M	1K-2M	1K-2M	2K-4M	2.5K-5M
DV3THB						160-4M	800-20M	1.6K-40M	1.6K-40M	3.2K-80M	4K-100M	
DV2THB						200-4M	1K-20M	2K-40M	2K-40M	4K-80M	5K-100M	
HBDV-IP						400-1.3M	2K-6.7M	4K-13.3M	4K-13.3M	8K-26.7M	10K-33.3M	
HBDVE						400-1.3M	2K-6.7M	4K-13.3M	4K-13.3M	8K-26.7M	10K-33.3M	
HBT						400-800K	2K-4M	4K-8M	4K-8M	8K-16M	10K-20M	

M = 1 million K = 1 thousand N = RPM e.g. Spindle SC4-18 1.32 x 10 (rpm) = 13.2 sec⁻¹ cP = Centipoise mPa•s = Millipascal-seconds

N/A = Not applicable for historical reasons. However, it is possible to use any spindle/chamber combination with any torque range. Digital viscometers/rheometers will automatically calculate viscosity.

* Examples

SC4-13R Sample Chamber

SC4-13RPY Sample Chamber with RTD temperature probe and cable to viscometer/rheometer

SC4-27 Stainless Steel Spindle

† Disposable chamber available in 13R size and requires SC4-45YD water jacket

SC4-13RP Sample Chamber with RTD temperature probe

SC4-13RD-100 Disposable Sample Chamber available in packages of 100

SC4-27D Disposable Spindle

Note: Hastelloy C available for some spindles/chambers - call for details

Removable Sample Chamber

The design of the Small Sample Adapter allows the sample chamber to be easily changed and cleaned without disturbing the set-up of the viscometer or temperature bath. This means that successive measurements can be made under identical conditions.

Temperature Control

The sample chamber fits into a water jacket so that precise temperature control can be achieved when the Brookfield circulating temperature bath is used. The stirring action of the rotating spindle, plus the small sample volume, helps to keep the temperature gradient across the sample to a minimum. Direct readout of sample temperature is provided using sample chambers with optional embedded RTD sensor connected to the DV-I Prime and DV2T Viscometers and the DV3T Rheometer. Working temperature range for the Small Sample Adapter is from 1°C to 100°C.

Cylindrical Geometry

The Small Sample Adapter's coaxial cylinder geometry provides extremely accurate viscosity measurements at defined shear rates.

Disposable Sample Chambers and SC4-27D Spindle

Disposable 13R chambers, for hard-to-clean materials, are available in a kit that comes complete with 100 chambers and special-sized water jacket (Part No. SSA-DCU). Additional disposable chambers can be purchased in quantities of 100 (Part No. SC4-13RD-100).

EZ-Lock Option

Small Sample Adapter is now available with special EZ-Lock spindle coupling for use on standard Brookfield Viscometers/Rheometers already equipped with the EZ-Lock feature.



Water jacket allows rapid and precise temperature control of sample

Sample chamber easily changed - slides into water jacket and locks in place

Simultaneous sample temperature measurement is possible by ordering embedded temperature probe in sample chamber

Optional disposable chamber also available

Enhanced UL Adapter™

ideal for low viscosity materials

Reduces measuring range

to as low as 1 cP, depending on viscometer used

Simple attachment

to a standard Brookfield Viscometer or DV3T Rheometer

Small sample size:

16 mL

Cylindrical geometry

provides defined shear rates for detailed product analysis

Removable cap

of low density polyethylene can be considered disposable for one-time use if required

Stainless steel parts

are easily cleaned



What's Included?

Locating Channel Assembly
Spindle (304 s/s) (p46)
with universal coupling nut
Collar assembly with thumbwheel
Water Jacket
Chamber Tube
Tube End Caps (package of 6)

Optional Accessories

Available with EZ-Lock spindle coupling (p50)



Closed Tube and Spindle
made from 316 s/s

The Brookfield Enhanced UL Adapter is used with any standard Brookfield Viscometer and Rheometer to make accurate and reproducible measurements on low viscosity materials. Newtonian and non-Newtonian materials can be measured. It is most commonly used with the LV series instrument (at 60 rpm, these models have a full scale range of 1-10 cP with the UL Adapter). The UL Adapter consists of a precision cylindrical spindle rotating inside an accurately machined tube. Its rheologically correct cylindrical geometry provides extremely accurate viscosity measurements and shear rate determinations.

The tube has a removable end cap which allows the open ended tube to be used in a beaker or tank. With the cap in place, the closed tube can be immersed in a temperature bath or used with the ULA-40Y water jacket for precise temperature control. Working temperature range is from 1°C to 65°C. Use Closed Tubes for higher temperature requirements

Quick & Easy Design Saves Time



Quick & easy attachment of spindle:

Longer coupling nut for better grip and twist action to connect spindle to viscometer.

Redesigned bracket for attaching ULA assembly to viscometer. Provides more clearance for finger grip on coupling nut.



Quick & easy removal of chamber:

Simply loosen thumbwheel, chamber slides down and out.

Permits rapid testing of multiple samples by swapping out chambers.

Choice of leaving spindle attached to viscometer or disconnecting spindle and removing it with chamber.

Water jacket sleeve remains in place attached to viscometer while chamber and/or spindle only are removed. Saves set up time for the operator.



Detail of UL Adapter: 1. Locating Channel Assembly, 2. Water Jacket, 3. Chamber Tube, 4. Collar with thumbwheel, 5. Tube End Cap, 6. Spindle with universal coupling

EZ-Lock Option

Enhanced UL Adapter is available with special EZ-Lock spindle coupling for use on standard Brookfield Viscometers/Rheometers already equipped with the EZ-Lock feature. (p50)

Unique ULA Assembly Design Provides Multiple Benefits:

Sturdy collar attaches to locating channel assembly which is connected to viscometer pivot cup.

Sample chamber is held firmly in place by the collar which provides proper alignment for the spindle rotation within the chamber.

Universal coupling nut on spindle ensures firm connection with viscometer and automatic self-centering of spindle in chamber during rotation.

Direct immersion of chamber in temperature bath is quick and easy.

Water jacket grips slide over collar and operator manually aligns the collar/jacket assembly to allow easy insertion of chamber containing sample to be tested.

UL Adapter Ranges cP(mPa•s)

LVT, LVDV-E, LVDV-IP DV2TLV, DV3TLV	RVT, RVDV-E RVDV-IP	DV2TRV DV3TRV	HAT, HADV-E HADV-IP	DV2THA DV3THA	HBT, HBDV-E HBDV-IP	DV2THB DV3THB
1.0 - 2K	6.4 - 2K	3.0 - 2K	12.8 - 2K	6.0 - 2K	51.2 - 2K	24.0 - 2K

K = 1 thousand

Helipath Stand™

designed for measurement of non-flowing substances



For viscosity/consistency measurement of gels, pastes, creams, putty, gelatin and other non-flowing substances.

A Brookfield Viscometer or Rheometer is mounted on the Helipath drive motor and a T-bar spindle is attached to the viscometer using a special coupling. The drive motor slowly lowers or raises the viscometer so that the T-bar spindle creates a helical path through the test sample thus eliminating the problem of “channeling”.

Compatible with standard Brookfield Viscometers and DV3T Rheometers

Simple to set up and clean

Provides a solution for hard-to-measure materials

Complete with drive motor, 6 T-bar spindles with coupling, case, lab stand, rod and base

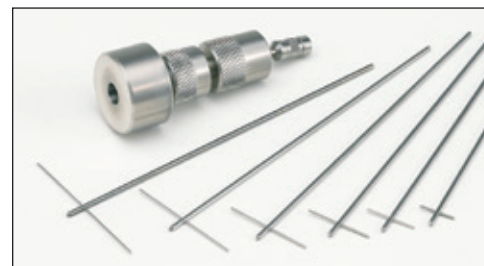

The Helipath Stand can be used with any standard Brookfield Viscometer model, and is supplied complete with a set of six T-bar spindles and a special coupling.

EZ-Lock Option

Helipath Stand is now available with special EZ-Lock spindle coupling for use on standard Brookfield Viscometers/ Rheometers already equipped with the EZ-Lock feature. (p50)

Helipath Viscosity Ranges cP(mPa•s)

	DIAL, DV-E, DV-IP	DV2T	DV3T
LV Viscosity Range	156 - 3,120K	156 - 9,360K	156 - 9,360K
RV Viscosity Range	2K - 20M	2K - 100M	2K - 100M
HA Viscosity Range	4K - 40M	4K - 200M	4K - 200M
HB Viscosity Range	16K - 160M	16K - 800M	16K - 800M

** Maximum range shown is at 0.1 rpm K = 1 thousand M = 1 million cP = Centipoise mPa•s = milliPascal•seconds

Vane Spindles

for foods, cosmetics, sealants...

...for use with paste-like materials, gels and fluids where suspended solids migrate away from the measurement surface of standard spindles.

Minimal disruption of sample during spindle immersion

Keeps particles in suspension during testing cycle

Viscosity data includes complete flow curve analysis when software is used

Provides information on yield behavior at low rotational speeds

Follows industry recommendations on length/diameter ratios for vane spindles

3-piece spindle set for versatile range capability

Optional V-74 and V-75 spindles for even greater range capability and immersion into small size sample containers



Vane Spindle Ranges

SPINDLE	TORQUE RANGE	SHEAR STRESS RANGE (Pa)	VISCOSITY RANGE cP(mPa*s)
V-71	NOT RECOMMENDED FOR USE ON LV TORQUE		
V-72	LV	.188-1.88	104.04-1.04K
V-73	LV	.938-9.38	502-5.02K
V-74	LV	9.38-93.8	5.09K-50.9K
V-75	LV	3.75-37.5	1.996K-19.96K
V-71	RV	.5-5	262-2.62K
V-72	RV	2-20	1.11K-11.1K
V-73	RV	10-100	5.35K-53.5K
V-74	RV	100-1K	54.3K-543K
V-75	RV	40-400	21.3K-213K
V-71	HA	1-10	524-5.24K
V-72	HA	4-40	2.22K-22.2K
V-73	HA	20-200	10.7K-107K
V-74	HA	200-2K	108.6K-1.086M
V-75	HA	80-800	42.6K-426K
V-71	HB	4-40	2.096K-20.96K
V-72	HB	16-160	8.88K-88.8K
V-73	HB	80-800	42.8K-428K
V-74	HB	800-8K	434.4K-4.344M
V-75	HB	320-3.2K	170.4K-1.704M
V-71	5xHB	20-200	10.48K-104.8K
V-72	5xHB	80-800	44.4K-444K
V-73	5xHB	400-4000	214K-2.14M
V-74	5xHB	4K-40K	2.172M-21.72M
V-75	5xHB	1.6K-16K	852K-8.52M

Note: 1. 1 Pa = 10 dyne/cm² 2. Viscosity Range is given at rotational speed of 10 RPM
3. 5xHB is the highest torque range available 4. Not for use with DV-E Viscometers

M = 1 million K = 1 thousand Pa = Pascal
cP = Centipoise mPa*s = Millipascal*seconds

Brookfield Vane Spindle Set

Includes V-71, V-72, and V-73 vane spindles. See the individual specifications in the spindle section. (p44)

Optional V-74 and V-75 spindles are smaller in size than V-73.

EZ-Lock Option

Vane Spindles are available with special EZ-Lock spindle coupling for use on standard Brookfield Viscometers/ Rheometers already equipped with the EZ-Lock feature. (p50)

DIN Adapter

Complies with DIN 53019 requirements for test geometry. DIN is the German equivalent to the U.S. ASTM Standards.

Designed to provide an alternative for those customers having limited sample volume. Requires 16 mL to 20 mL sample size.

Cylindrical geometry provides defined shear rates.

Comes with three spindles and chambers for measurement range of 1 to 50,000 cP.



DIN Adapter Set

EZ-Lock Option

DIN Spindles are available with special EZ-Lock spindle coupling for use on standard Brookfield Viscometers/ Rheometers already equipped with the EZ-Lock feature. (p50)

DIN Adapter Ranges cP(mPa•s)

LVT	LVDV-E LVDV-IP	DV2TLV DV3TLV	RVT, RVDV-E RVDV-IP	DV2TRV DV3TRV	HAT, HADV-E HADV-IP	DV2THA DV3THA	HBT, HBDV-E HBDV-IP	DV2THB DV3THB
1.9 - 37.9K	1.2 - 37.9K	1.0 - 50K	12.2 - 50K	5.0 - 50K	24.4 - 50K	10.0 - 50K	97.6 - 50K	40.0 - 50K

K = 1 thousand cP = Centipoise mPa•s = Millipascal•seconds

Spiral Adapter

Designed for measuring the viscosity of heavy paste-like materials such as solder paste, cosmetics, pharmaceuticals, food products and other non-flowing products. Provides variable shear rates for detecting pseudoplastic and thixotropic behavior.

The spiral adapter is mounted onto a Brookfield Viscometer; with the chamber immersed in the test sample and the motor turned on, material is “pumped thru” and reaches a steady flow rate. Shear rate is 0.677 sec⁻¹ per rpm.



Spiral Adapter Set

Compatible with standard Brookfield Viscometers & DV3T Rheometers

Compatible with electronics industry solder paste specifications

Complete with chamber, two spindles, assembly clamp and case

Note: RV/HA/HB torque ranges recommended

Spiral Adapter Ranges cP(mPa•s)

LV Series	to 100K
RV Series	to 1.1M
HA Series	to 2.2M
HB Series	to 9.0M

K = 1 thousand M = 1 million cP = Centipoise mPa•s = milliPascal•seconds

Spindles

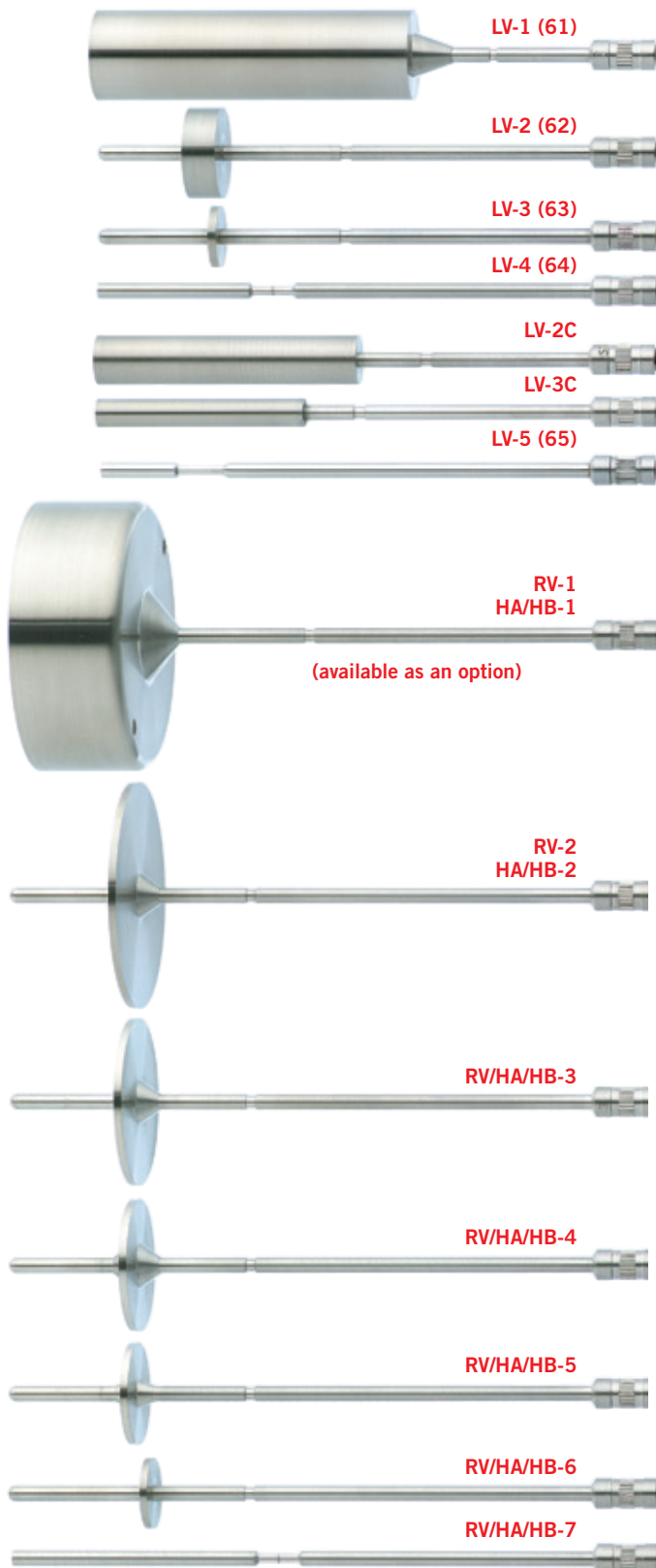

LV Spindles cP(mPa•s)	
SPINDLE	RANGE*
LV-1 (61)	15 - 20K
LV-2 (62)	50 - 100K
LV-3 (63)	200 - 400K
LV-4 (64)	1K - 2M

LV-5 (65)	2K - 4M	LV-5 is an optional spindle designed to increase measuring range.
LV-2C	50 - 100K	
LV-3C	200 - 400K	

* Based on Standard LV speeds .3 - 60 rpm M = 1 million K = 1 thousand
 Note: LV-1 through LV-4 are supplied with LV instruments.
 LV-2C & LV-3C are optional "cylindrical spindles" offering geometry for calculating shear rates.
 LV and RV/HA/HB spindles are supplied in 302 stainless steel.
 Optional 316 stainless or teflon coated spindles are available

RV/HA/HB Spindles cP(mPa•s)			
SPINDLE	RANGE* RV SERIES	RANGE* HA SERIES	RANGE* HB SERIES
RV-1 **	100 - 20K	200 - 40K	800 - 160K
HA/HB-1 **	100 - 20K	200 - 40K	800 - 160K
RV-2	100 - 80K	200 - 160K	800 - 640K
HA/HB-2	100 - 80K	200 - 160K	800 - 640K
RV/HA/HB-3	100 - 200K	200 - 400K	800 - 1.6M
RV/HA/HB-4	200 - 400K	400 - 800K	1.6K - 3.2M
RV/HA/HB-5	400 - 800K	800 - 1.6M	3.2K - 6.4M
RV/HA/HB-6	1K - 2M	2K - 4M	8K - 16M
RV/HA/HB-7	4K - 8M	8K - 16M	32K - 64M

* Based on standard RV/HA/HB speeds .5-100 RPM. M = 1 million K = 1 thousand
 Note: LV and RV/HA/HB spindles are supplied in 302 stainless steel.
 Optional 316 stainless or teflon coated spindles are available
 ** This spindle available as an option



RV/HA/HB Spindle Set includes spindles #2 - #7 and is supplied with standard Brookfield Viscometers and Rheometers.

Spindle #1 is available as an option.

Spindle Rack is also available as an option with both LV and RV/HA/HB spindle sets.

Spindles

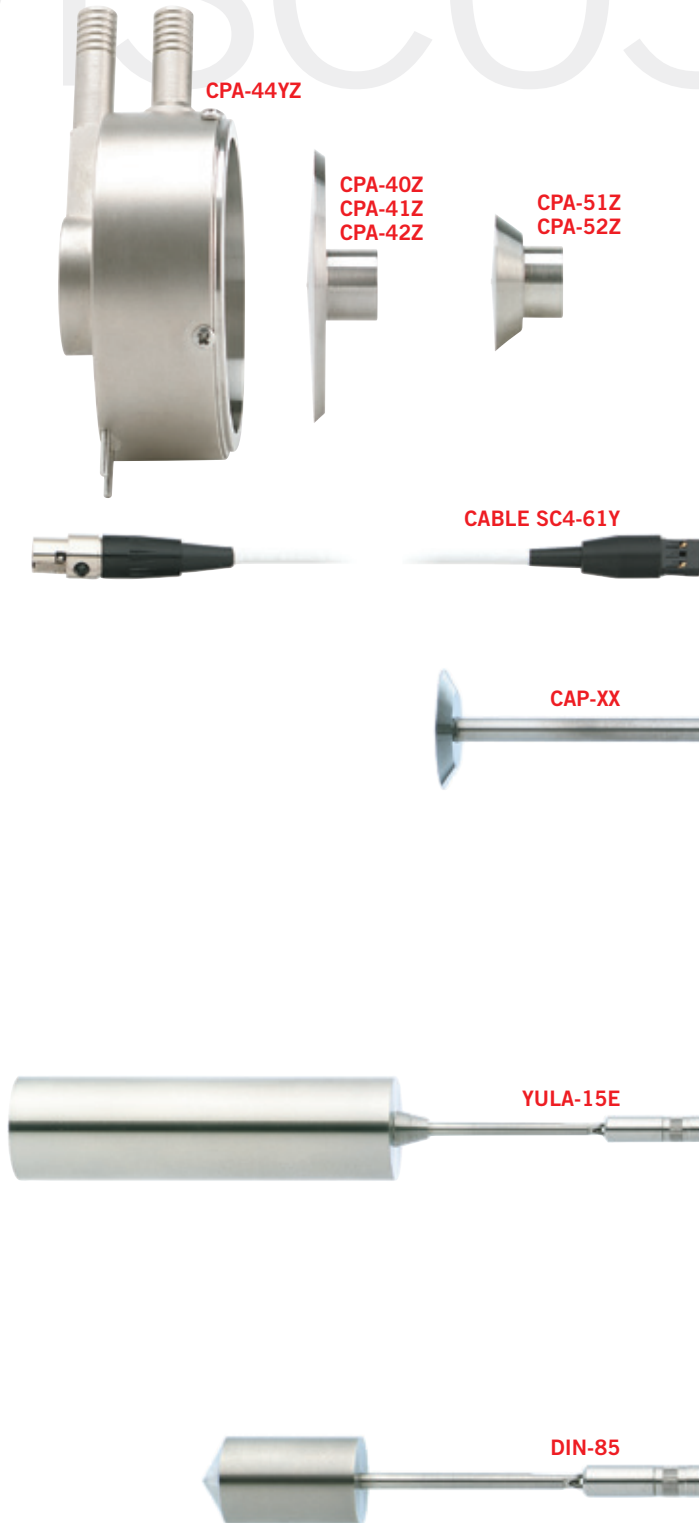

Wells/Brookfield Spindles & Cups

SPINDLE	SHEAR RATE	SAMPLE VOLUME	CONE ANGLE	CONE RADIUS
CPA-40Z	7.50N sec ⁻¹	.5mL	.8°	2.4cm
CPA-41Z	2.00N sec ⁻¹	2.0mL	3°	2.4cm
CPA-42Z	3.84N sec ⁻¹	1.0mL	1.5°	2.4cm
CPA-51Z	3.84N sec ⁻¹	.5mL	1.5°	1.2cm
CPA-52Z	2.00N sec ⁻¹	.5mL	3°	1.2cm
CUP				
CPA-44YZ	Standard cup without temperature probe			
CPA-44PYZ	Standard cup with RTD temperature probe			
PCPA-3YZ	Cup with 1 purge fitting			
PCPA-6YZ	Cup with luer fitting and 1 purge fitting			
PCPA-4YZ	Cup with luer fitting and 2 purge fittings			
PCPA-7YZ	Cup with luer fitting and 4 purge fittings			

- Note: 1. Wells-Brookfield cones and cups are calibrated at the factory.
 Cones ordered after shipment require cups to be returned for calibration to new cone.
 2. CPA cups and spindles are compatible with CPE cups and spindles
 3. See page 18 for viscosity ranges

CAP Spindles

SPINDLE	SHEAR RATE	SAMPLE VOLUME	CONE ANGLE	CONE RADIUS
CAP-01	13.3N sec ⁻¹	67 µL	0.45°	1.511cm
CAP-02	13.3N sec ⁻¹	38 µL	0.45°	1.200cm
CAP-03	13.3N sec ⁻¹	24 µL	0.45°	0.953cm
CAP-04	3.3N sec ⁻¹	134 µL	1.8°	1.200cm
CAP-05	3.3N sec ⁻¹	67 µL	1.8°	0.953cm
CAP-06	3.3N sec ⁻¹	30 µL	1.8°	0.702cm
CAP-07	2.0N sec ⁻¹	1700 µL	3.0°	2.399cm
CAP-08	2.0N sec ⁻¹	400 µL	3.0°	1.511cm
CAP-09	2.0N sec ⁻¹	100 µL	3.0°	0.953cm
CAP-10	5.0N sec ⁻¹	170 µL	1.2°	1.511cm

- Note: 1. Recommend ordering calibration fluids specific to cone for field calibration
 2. See page 21 for viscosity ranges

UL Spindles & Chambers

SPINDLE	TYPE	SAMPLE VOLUME	SHEAR RATE
YULA-15(E)	Spindle - 304 stainless steel		1.224N
YULA-15(E)Z	Spindle - 316 stainless steel		1.224N
ULA-31(E)Y	Sample Chamber - 304 stainless steel	16mL	
ULA-31(E)YZ	Sample Chamber - 316 stainless steel	16mL	

- Note: 1. See page 41 for viscosity ranges
 2. (E) represents enhanced UL version (introduced Jan. 2006) N = rpm

DIN Spindles

SPINDLE	SHEAR RATE	SAMPLE VOLUME
ULA-DIN-85	1.29N	17.0mL
ULA-DIN-86	1.29N	6.5mL
ULA-DIN-87	1.29N	2.0mL
HT-DIN-81 for Thermosel	1.29N	7.0mL
SC4-DIN-82 for SSA	1.29N	1.5mL
SC4-DIN-83 for SSA	1.29N	1.5mL
CHAMBER		
ULA-DIN-6Y	for use with ULA-DIN-86 and 87	
DAA-1	for use with ULA-DIN-85	



CCT-XX



RCT-XX-X



VT-80-40



RSS-90Y (1-4000BU)



SC4-XXBS SOLID SHAFT*



SC4-XX LINK HANGING



HT-2



HT-2DB-100



CHAMBER RACK HT-54

Call or visit our website for more information on spindles with EZ-Lock connectors.

RST Spindles

SPINDLE	VISCOSITY RANGE	SHEAR RATE	MAX. SHEAR STRESS	SAMPLE VOLUME
COAXIAL	Pa*s	sec ⁻¹	Pa	mL
CCT-DG	0.00005-4.07K	0.043-5.64K	177	15.7
CCT-40	0.0003-27.6K	0.0215-2.79K	594	68.5
CCT-25	0.002-177K	0.013-1.67K	2.28K	16.8
CCT-14	0.012-1M	0.013-1.68K	13K	3.4
CCT-8	0.065-5.41M	0.013-1.672K	69.6K	1.0
CONE				
RCT-25-1	0.005-407K	0.06-7.8K	24.4K	0.1
RCT-25-2	0.01-814K	0.03-3.9K	24.4K	0.2
RCT-50-1	0.0006-50.9K	0.06-7.8K	3.05K	1.0
RCT-50-2	0.0012-101K	0.03-3.9K	3.05K	2.0
RCT-75-1*	0.0002-15K	0.06-7.8K	905	2.5
RCT-75-2*	0.0004-30K	0.03-3.9K	905	5.0
PLATE				
RPT-25	0.03-2.49M	0.013-1.7K	32.6K	0.5
RPT-50	0.002-155K	0.027-3.4K	4.07K	2.0
RPT-75*	0.0004-30.7K	0.04-5.1K	1.2K	4.5

*For use with water bath version only 1 Pa*s = 1,000 cP K = 1 thousand M = 1 million
Note: Values based on minimum speed of 1 RPM and maximum speed of 1000 RPM

RST Vane Spindles

SPINDLE	VANE LENGTH	VANE DIAMETER	SHEAR STRESS
	mm	mm	Pa
VT-10-5	10	5	330-210K
VT-20-10	20	10	41-27K
VT-20-20	20	20	9-5.9K
VT-30-15	30	15	12-8K
VT-40-20	40	20	5.2-3.4K
VT-40-40	40	40	1.2-740
VT-50-25	50	25	2.7-1.7K
VT-60-8	60	8	24-15K
VT-60-15	60	15	7-4.3K
VT-60-30	60	30	1.6-1K
VT-80-40	80	40	0.7-420
VT-80-70	80	70	0.2-120

Values based on minimum speed of 1 RPM and maximum speed of 1000 RPM K = 1 thousand

Thermosel Spindles and Chambers

Link hanging configuration is standard

SPINDLE	SHEAR RATE	SAMPLE VOLUME
SC4-18	1.32N	8.0mL
SC4-31	.34N	10.0mL
SC4-34	.28N	9.5mL
SC4-21	.93N	8.0mL
SC4-27**	.34N	10.5mL
SC4-28	.28N	11.5mL
SC4-29	.25N	13.0mL
HT-DIN-81	1.29N	7.0mL

*SC4-XXBS = Solid Shaft. Not available for SC4-18 and SC4-21 spindles

**Also available as SC4-27D-100 = Disposable spindle, 100 units

CHAMBER	TYPE
HT-2	Sample Chamber - Reuseable, stainless steel
HT-2DB-100	Sample Chamber - Disposable, aluminum, 100 units

Note: See page 37 for spindle ranges

Spindles



Required for SC4-27D disposable spindles: **SC4-DSY CHUCK/CLOSER**

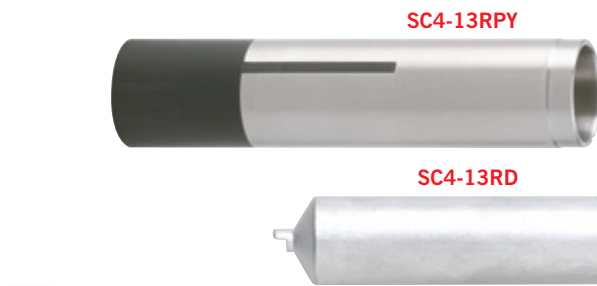

Small Sample Spindles and Chambers

SPINDLE	SHEAR RATE	SAMPLE VOLUME
SC4-18	1.32N	6.7 mL
SC4-31	0.34N	9.0 mL
SC4-34	0.28N	9.4 mL
SC4-16	0.29N	4.2 mL
SC4-25Z (316 s/s only)	0.22N	16.1 mL
SC4-21†	0.93N	7.1 mL
SC4-27*†	0.34N	10.4 mL
SC4-15	0.48N	3.8 mL
SC4-28	0.28N	11.0 mL
SC4-29	0.25N	13.5 mL
SC4-14	0.40N	2.1 mL
SC4-DIN-82	1.29N	1.5 mL
SC4-DIN-83	1.29N	1.5 mL

CHAMBER	TYPE
SC4-13R	Sample Chamber w/o temperature probe
SC4-13RPY	Sample Chamber w/RTD temperature probe & cable
SC4-8R	Sample Chamber w/o temperature probe
SC4-8RPY	Sample Chamber w/RTD temperature probe & cable
SC4-7R	Sample Chamber w/o temperature probe
SC4-7RPY	Sample Chamber w/RTD temperature probe & cable
SC4-6R	Sample Chamber w/o temperature probe
SC4-6RPY	Sample Chamber w/RTD temperature probe & cable
SC4-13RD-100‡	Sample Chamber - Disposable, aluminum, 100 units

Note: See page 39 for spindle/chamber ranges ‡ Requires the use of special water jacket SC4-45Y
 * Also available as SC4-27D-100 = Disposable spindle, 100 units
 † Solid shaft option available for spindles SC4-21 (Part No. SC4-21SD) and SC4-27 (Part No. SC4-27SD).

KU-2 Spindles

SPINDLE	TYPE
KU1-10	Standard Krebs Spindle
KU1-75Y	Optional Paste Spindle

T-Bar Spindles cP(mPa•s)

SPINDLE	LV	RV	HA	HB
T-A	156 - 62.5K	2K - 400K	4K - 800K	16K - 3.2M
T-B	312 - 124.8K	4K - 800K	8K - 6M	24K - 6.4M
T-C	780 - 312K	10K - 2M	20K - 4M	80K - 16M
T-D	1.5K - 624K	20K - 4M	40K - 8M	160K - 32M
T-E	3.9K - 1.5M	50K - 10M	100K - 20M	400K - 80M
T-F	7.8K - 3.1M	100K - 20M	200K - 40M	800K - 160M

M = 1 million K = 1 thousand

Spiral Adapter Spindle

SPINDLE	CHAMBER
SA-70	SA-1Y

Note: See page 44 for ranges

Vane Spindles

SPINDLE	VANE LENGTH (in)	VANE DIAMETER (in)
V-71	2.708	1.354
V-72	1.706	.853
V-73	.998	.499
V-74	.463	.232
V-75	.632	.316

Note: Container diameter should be twice (2x) the vane diameter when possible. See page 43 for ranges.

Options & Specialty Items



MVS-1Y

MVS-1Y Flag Impeller Spindle

Use with the Small Sample Adapter to help keep sample materials in suspension



4B2

4B2 Spindle

Required for viscosity testing in accordance with ASTM D2983 (Low Temperature Viscosity Measurement of Automotive Fluid Lubricants)



ABZ

ABZ Spindle

Used for viscosity testing of thick film pastes. Short spindle length is suitable for immersion into shallow depth containers. Sensing length of spindle is less than 1-inch (2.54cm).

ABZ Spindle

RV	HA	HB
8K-16M	16K-32M	64K-138M

Custom Spindles

Custom spindles can be developed to meet your particular test requirements. Contact Brookfield or an authorized dealer for details.



SP1-UC-Y

YDX-1

Type D Extension Link with Hook Coupling

YDX-1	Male coupling nut; attaches to spindle
SP1-UC-Y	Female coupling nut; attaches to viscometer
SXV-XX	Extension link; see below for lengths



SXL-X

SP1-UC-Y

SXR-X

Type S Spindle with one SPU-UCY coupling

SPINDLE	
SXL-X	Type S LV spindle (1-4)
SXR-X	Type S RV/HA/HB spindle (1-7)



EXTENSION LINK SXV-XX

Extension

LINK	LENGTH	USED WITH
SXV-08	1"	UL Adapter
SXV-09	1.12"	Small Sample Adapter
SXV-24	3"	Thermosel
SXV-32	4"	Type D/S Extension
SXV-48	6"	Type D/S Extension
SXV-80	10"	Type D/S Extension
SXV-96	12"	Type D/S Extension

Note: Other lengths available; call for details



SP-7Y QUICK CONNECT COUPLING

SP-4

SP-3

SP-5

Quick Connect Coupling (SP-7Y)

PART	
SP-3	Coupling to viscometer/rheometer
SP-4	Coupling to spindle
SP-5	Sleeve (to hold together)

Call or visit our website for more information on spindles with EZ-Lock connectors.

Options & Specialty Items

Model A Lab Stand: Dial, DV-E

Model G Lab Stand: DV3T, DV2T, DV-I Prime, YR-1

All standard viscometers — and the YR-1 Rheometer — are supplied with either a Model A or Model G Laboratory Stand. These traditional stands move the viscometer up and down by turning the knob on the 14 inch rod* and clamp assembly. The clamp itself has been newly redesigned to allow for an easier, more ergonomic grip.

*Lab Stands with 18 inch rod assemblies are also available for testing with baths.
Part Numbers for 18" stands: Model A 18, Model G 18



MODEL A
LAB STAND



MODEL G
LAB STAND

Quick Action Lab Stand:

Optional purchase for Dial, DV-E, DV-I Prime & YR-1



MODEL Q LAB STAND

Taking measurements has never been so fast or easy! With the push of a button, the instrument moves up and down the lab stand, quicker and easier than ever before. The Quick Action Lab Stand is perfect for busy lab environments, especially those with multiple operators or multiple samples. This stand is available as an option for new Dial, DV-E, and DV-I Prime Viscometers and is also compatible with existing models.

EZ-Lock Spindle Coupling System



Quickly and more safely change spindles with this spring-loaded spindle coupling attachment. Attach the EZ-Lock Spindle Coupling to a spindle and insert the spindle into the chuck. That's it! Changing spindles has never been quicker or easier...making this the perfect option for busy labs with multiple samples to test. EZ-Lock can be purchased as an option for new DV-I Prime and DV2T Viscometers as well as the DV3T Rheometer. It can also be retrofitted to your existing DV-I and DV-II series Viscometer as well as any of your DV-III series Rheometers.

EZ-Lock is also available for use with your favorite Brookfield accessories such as the Thermosel and Helipath Stand as well as the following adapters: Small Sample Adapter, UL Adapter, Enhanced UL Adapter and DIN Adapter.*

* Special brackets may be required to accommodate the length of the EZ-Lock system; requirement can be determined at time of ordering.

Ball Bearing Option

If your viscometer or rheometer is used by multiple operators or in a busy lab environment, a more durable ball bearing suspension system may help keep your instrument in calibration longer with less "down time". This option can be ordered at the time of purchase and a retrofit to existing instruments may be available. Consult Brookfield or your local Brookfield representative for details.**

** This option is for the torque ranges of RV, HA, and HB only - it is not available for instruments in the LV torque range.

Protective Keypad Covers



Protect your keypad against dirt, scratches, spillage and dust with these “peel and stick” disposable covers. They are ideal for instruments with multiple users and for busy, high traffic work areas. These flexible protective covers are packaged in quantities of 10 and are available for most DV-I series, DV-II series, CAP series, DV-III series, YR-1, VTE series and AST-300SY touch screen controller models.

Complimentary Torque Decals

Now you can quickly identify the torque range of your standard Brookfield Viscometer/Rheometer with easy-to-read decals. The decals provide a convenient labeling system for your lab or production personnel. The label sheet comes with pressure-sensitive decals, two large and two small for LV, RV, HA and HB torque ranges. The small decals fit on the instrument faceplate and the large decals the on the side, back or top of the instrument. These free decals are also available for CAP series Viscometers.



Dymo 450 Turbo Label Writer

Easily print — and permanently record — test data with this compact Dymo 450 turbo label writer for DV2T Viscometers and DV3T Rheometers. It comes complete with three convenient continuous feed paper rolls:

Paper roll, 2 1/4" wide x 300' (Reorder: GV-1047)

Adhesive label roll, 1 1/8" x 3 1/2", 350 labels per roll (Reorder: GV-1048)

Adhesive label roll, 2 5/16" x 4", 300 labels per roll (Reorder: GV-1049)



Touch Screen Protectors

Easy to apply Touch Screen Protectors to shield against dust and dirt are now available for DV2T Viscometers (Part No. GV-1019) and DV3T Rheometers (Part No. GV-1020). Each package includes two touch screen protectors, an application tool for easy alignment, and a cleaning cloth. It's no-water-required application method ensures a no mess, smooth application.



The Brookfield Website

Looking for more information? Then the Brookfield website is the place to visit. Here you can download manuals, MSDSs, article reprints, and brochures. Find representatives in your area or register your instrument online. Find out when our popular training series will be in your area or watch our, free online videos. The website is updated frequently so there's always something new to discover at www.brookfieldengineering.com.



Viscosity Standards

Brookfield Viscosity Standards provide a convenient, reliable way to verify the calibration of your Brookfield Laboratory Viscometer/Rheometer. Brookfield Viscosity Standards are

Newtonian, and they are available as either silicone or oil. Silicone fluids are less temperature sensitive than oil fluids.

Note: Brookfield recommends that all fluids be replaced annually

Silicone Viscosity Standards

These fluids are most commonly used to verify calibration of Brookfield Viscometers/Rheometers.

Accuracy: ±1% of viscosity value

Excellent temperature stability

Recommended for use with Brookfield and most other rotational viscometers

Most economical

Special viscosity values and temperature calibrations available upon request



VisCal Kit

The Brookfield VisCal Kit provides all the necessary items to verify calibration of your Viscometer/Rheometer. Includes Brookfield 600mL Beaker, 1 pint of Silicone Viscosity Standard, Dispensing Bottle for cleanup and Trapper Cleaning Agent.*

*Trapper Cleaning Agent available only in shipments within the USA



Plastic VisCal Kit

The Brookfield Plastic VisCal Kit provides all the necessary items to verify calibration of your Viscometer/Rheometer in a glass-free environment. Includes Brookfield 600mL Plastic Beaker, 1000ml of Silicone Viscosity Standard (5-12,500 cP) in a plastic bottle and a Brookfield-designed metal lid for anchoring beaker in the temperature bath.



General Purpose Silicone Fluids		
Brookfield Part #	Nominal Viscosity cP (mPa•s)	Temp °C
5 cps	5	25.0°C
10 cps	10	25.0°C
50 cps	50	25.0°C
100 cps	100	25.0°C
500 cps	500	25.0°C
1000 cps	1,000	25.0°C
5000 cps	5,000	25.0°C
12500 cps	12,500	25.0°C
30000 cps	30,000	25.0°C
60000 cps	60,000	25.0°C
100000cps	100,000	25.0°C

High Temperature Silicone Fluids			
Brookfield Part #	Nominal Viscosity cP (mPa•s)	Temp °C	Temp °F
HT30000	30,000	25.0°C	77°F
	9,000	93.3°C	200°F
	4,500	149.0°C	300°F
HT60000	60,000	25.0°C	77°F
	18,000	93.3°C	200°F
	9,000	149.0°C	300°F
HT100000	100,000	25.0°C	77°F
	30,000	93.3°C	200°F
	15,000	149.0°C	300°F

Special Order Silicone Fluids

For our customers needing a nonstandard viscosity or temperature range, our silicone fluids can be modified to meet most requirements.

VISCOSITY BLENDS CALIBRATED AT 25°C (77°F)

- Minimum: 5 cP (mPa•s)
- Maximum: 60,000 cP (mPa•s)
- Blends will be within ±2% of requested value

TEMPERATURE CALIBRATIONS

- Minimum: 10°C (50°F)
- Maximum: 80°C (176°F)
- Minimum temperature increment: 2°C

Oil Viscosity Standards

These fluids are used for specific instruments using cone/plate or Krebs spindle geometry. Also, certain industries may require use of oil standards.

Accuracy: ±1% of viscosity value

Appropriate for use at shear rates greater than 500 sec⁻¹

Recommended for use with cone/plate Viscometers at viscosities above 5,000 cP

Recommended for Brookfield CAP series and KU-2 Viscometers and RST Rheometers

Brookfield oil viscosity standards are hydrocarbon based, either mineral oil or polybutenes

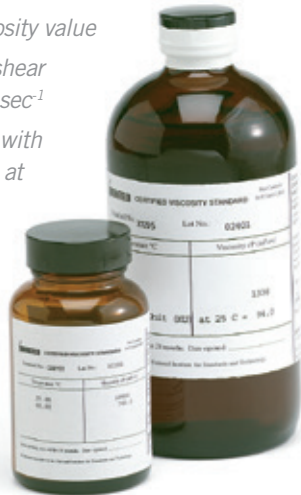

Note: Other oil fluids are available – call for details

Brookfield Viscosity Standards are accurate to ±1% of the stated viscosity and are certified by methods traceable to the United States National Institute of Standards and Technology (NIST). The selection of one or two fluids will normally provide sufficient measurement points to verify calibration of your instrument. All fluids are supplied in 1/2 liter (1 pint) containers complete with a certificate of calibration. CAP Oil Fluids are supplied in 150 mL (4 oz) containers

CAP Viscometer Oil Fluids For calibrating CAP Series cones each spindle has its own fluid

Cone Spindle	HIGH TORQUE CAP				LOW TORQUE CAP			
	Low Temp 25°C		High Temp 60°C		Low Temp 25°C		High Temp 60°C	
	Brookfield Part #	Viscosity cP (mPa•s)	Brookfield Part #	Viscosity cP (mPa•s)	Brookfield Part #	Viscosity cP (mPa•s)	Brookfield Part #	Viscosity cP (mPa•s)
1	CAP1L	89	CAP1H	89	CAP0L	57	CAP0H	57
2	CAP2L	177	CAP2H	177	CAP1L	89	CAP1H	89
3	CAP3L	354	CAP3H	354	CAP2L	177	CAP2H	177
4	CAP4L	708	CAP4H	708	CAP3L	354	CAP3H	354
5	CAP5L	1,417	CAP5H	1,417	CAP4L	708	CAP4H	708
6	CAP6L	3,542	CAP6H	3,542	CAP5L	1,417	CAP5H	1,417
7	CAP7L	1,328	CAP7H	1,328	CAP1L	89	CAP1H	89
8	CAP8L	5,313	CAP8H	5,313	CAP3L	354	CAP3H	354
9	CAP9L	21,250	CAP9H	21,250	CAP5L	1,417	CAP5H	1,417
10	CAP10L	236	CAP10H	236	CAP2L	177	CAP2H	177

HOW TO SELECT A CAP FLUID

- Determine which viscometer is being used: High Torque or Low Torque.
- Determine which temperature model is being used: Low Temperature (5°C-75°C) or High Temperature (50°C-235°C)
- Determine which cone is being used.

Krebs Viscometer Oil Fluids

Brookfield Part #	Nominal Viscosity Krebs Units	Temp °C
KU61	61	25.0°C
KU73	73	25.0°C
KU87	87	25.0°C
KU99	99	25.0°C
KU106	106	25.0°C

General Purpose Oil Fluids

Brookfield Part #	Nominal Viscosity cP (mPa•s)	Temp °C
B29	29	25.0°C
B200	200	25.0°C
B400	400	25.0°C
B600	600	25.0°C
B1060	1,060	25.0°C
B2000	2,000	25.0°C
B10200	10,200	25.0°C
B21000	21,000	25.0°C
B73000	73,000	25.0°C
B200000	200,000	25.0°C
B360000	360,000	25.0°C

RST Rheometer Oil Fluids (calibrated at 25.0°C)

Cone Spindle	Brookfield Part #	Nominal Viscosity cP (mPa•s)
RCT-25-1	B73000	73,000
RCT-25-2	B200000	200,000
RCT-50-1	B21000	21,000
RCT-50-2	B41000	41,000
RCT-75-1	B10200	10,200
RCT-75-2	B21000	21,000

RST Rheometer Oil Fluids (calibrated at 25.0°C)

Coaxial Spindle	Brookfield Part #	Nominal Viscosity cP (mPa•s)
CCT-DG	B200	200
CCT-40	B4900	4,900
CCT-25	B10200	10,200
CCT-14	B21000	21,000
CCT-8	B73000	73,000



texture analyzer



S

What is texture analysis?

Texture analysis is primarily concerned with measurement of the mechanical properties of a product, often a food product, as they relate to its sensory properties detected by humans. Fifty years of texture research has developed a set of definitions relating the sensory properties of a product to the instrumental properties which can be calculated from the results of a two cycle texture profile analysis test. Texture analyzers perform this test by applying controlled forces to the product and recording its response in the form of force, deformation and time.

These graphs show two ways of looking at the data from one 2 cycle Texture Profile Analysis test. The force vs time graph clearly shows the force peak resulting from each compression cycle, while the force vs distance graph better displays the response of the sample to the application and removal of strain.

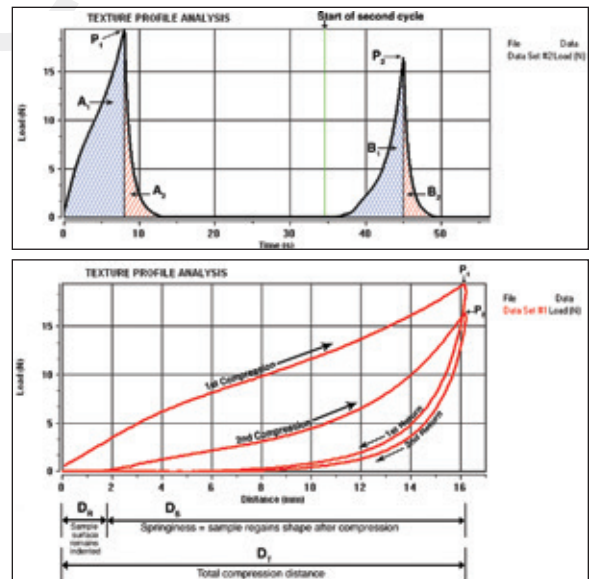

PARAMETERS	SENSORY DEFINITION	INSTRUMENTAL DEFINITION	
Hardness	Force required to compress a food between the molars. Defined as force necessary to attain a given deformation.	Peak force of the first compression cycle.	P_1
Springiness Index Preferred for comparing samples of different lengths	Ratio of the height the sample springs back after the first compression compared to the maximum deformation.	Springiness divided by total deformation.	$\frac{D_s}{D_T}$
Corrected Cohesiveness (PELEG, 1976)	Net work invested in the non-recoverable deformations of the first and second chews.	The ratio of the net work of the second cycle $B_1 - B_2$ divided by that of the first cycle $A_1 - A_2$.	$\frac{B_1 - B_2}{A_1 - A_2}$
Corrected Chewiness	The net energy required to chew a SOLID food to the point required for swallowing it.	The product of hardness, corrected cohesiveness and springiness index	$P_1 \times \left(\frac{B_1 - B_2}{A_1 - A_2} \right) \times \frac{D_s}{D_T}$
Resilience (PELEG, 1976)	Measurement of how a sample recovers from deformation in relation to speed and forces derived.	Resilience is the ratio of work returned by the sample as compressive strain is removed (known as recoverable work done A_2), to the work required for compression (known as hardness work done A_1).	$\frac{A_2}{A_1}$
Adhesiveness	The work necessary to overcome the attractive forces between the surface of the food and the surface of other materials with which the food comes into contact (e.g. tongue, teeth, palate). Work required to pull food away from a surface.	The negative area for the first bite, representing the work necessary to pull the compressing plunger away from the sample. (No adhesiveness is seen in graphs above.)	
Adhesive Force (Fizman and Damaio, 2000)	The maximum force required to separate teeth after biting sample.	Maximum negative force generated during probe return.	
Gumminess Applies to semi-solid products only if they have no springiness & undergo permanent deformation	Energy required to disintegrate a SEMI-SOLID food product to a state ready for swallowing. Related to foods with low hardness levels.	The product of hardness and cohesiveness.	$P_1 \times \frac{B_1}{A_1}$
Cohesiveness A measurement of how well the structure of a product withstands compression	The strength of internal bonds making up the body of the product (greater the value the greater the cohesiveness)	The ratio of the work during compression (downward stroke only) of the second cycle B_1 divided by that of the first cycle A_1 .	$\frac{B_1}{A_1}$
Chewiness Solid foods only	The energy required to chew a SOLID food to the point required for swallowing it.	The product of hardness, cohesiveness and springiness.	$P_1 \times \frac{B_1}{A_1} \times D_s$

Why Choose Brookfield?

Brookfield Engineering is recognized around the world as offering high quality measurement instruments at an affordable price. Unsurpassed customer support is but one more reason to choose a Brookfield product when you are considering a viscometer, rheometer, texture analyzer or a powder flow tester. To find out about the in-depth service that we provide, ask any customer who has uses one of our viscometers.

The CT3 offers the highest performance/cost ratio on the market. Distance accuracy is assured during calibration for each and every CT3 by storing the unique compensation curve for load cell deflection. Each load cell deflects naturally and uniquely as the force builds to the maximum range for the load cell. This unique deflection of each load cell is stored during calibration and applied to the drive system in real time as the test runs. This compensation assures accurate distance travel regardless of the load force recorded.

The CT3 Texture Analyzer utilizes uni-axial compression and tension forces in combination with a selection from our extensive list of probes, grips and fixtures to test a wide variety of food, personal care products and industrial materials. Most tests desire to imitate conditions imposed on these products during manufacture, handling, and consumption or use. Characterizing the physical properties of your products in such an analytical manner provides “real life” insight and can be invaluable toward maintaining consistent, high quality manufacturing while minimizing cost.

The Brookfield Texture Department can also provide customers with complete texture assessment service. We specialize in the development of novel and innovative test applications and accessories for solid and semi-solid materials, enabling our customers to maximize the practical value of their texture studies within all test environments.

Brookfield's compact design of the CT3 has a long heritage of more than 20 years dating from the Stevens gelatin Bloom tester. The CT3 still contains the Bloom test method and we now offer the complete gelatin bath preparation system along with GMIA and GME approved Bloom bottles. The system includes a CT3, a rack allowing easy handling of twelve Bloom bottles, two TC-450MX large reservoir baths and a TC-351 chiller.



CT3 Gelatin System

Why Measure Texture?

Consumer products succeed in the marketplace in part because their “textural characteristics” are pleasing to customers. This is certainly true with food products but it also applies to cosmetics, pharmaceuticals, packaging, industrial materials and even adhesive type materials.

Applications

Quality Control, Product Development and R & D

FOOD

Dairy	Bakery	Snack Foods	Meat	Fruit & Vegetables
Butter	Bread	Chips	Beef	
Cheese	Dough	Confections	Poultry	
Tofu	Pastry	Granola Bars	Seafood	
Yogurt			Surimi	

COSMETICS

Creams	Eye liner pencils	Lipstick
Mascara	Powder compacts	Soap bars

PHARMACEUTICALS

Adhesive dressing	Gelatins	Ointment	Syringe testing
Tablet hardness			

MATERIALS

Adhesives	Caulking	Grease	Packaging
Rubber	Wax		

Properties Measured

Adhesiveness	Apparent Modulus	Breaking Point
Burst Strength	Chewiness	Coefficient of Friction
Cohesiveness	Consistency	Elasticity
Fracture Force	Gel Strength	Gumminess
Hardness	Pliability	Relaxation
Ripeness	Spreadability	Tackiness
Yield Point		

CT3™ Texture Analyzer

compression and tension testing for rapid QC analysis

An extensive history and customer input have contributed to the development of the most powerful, low cost, stand-alone Texture Analyzer ever produced. With six test modes (plus calibration check) and a wide choice of accessories, no other texture analyzer has ever done so much without requiring a computer and software!

Standard Test Modes

Normal Test:

a single compression cycle

Hold Time Test:

compress and hold

Cycle Count Test:

compress multiple times

Bloom Test:

gelatin bloom strength test

TPA Test:

texture profile analysis

Tension Test:

tensile testing

Surimi Test:

gel strength

Static Load Test:

calibration check

Texture Loader Software

allows up to ten custom tests and ability to lock parameters

Compression distance

up to 10cm, can accommodate sample up to 22.5cm, almost 9 inches tall. Probe shaft is 8cm from back wall.

Choice of Load Cells

7 measurement ranges up to 50kg

Choice of Base Tables

allows for larger samples and more accessory choices



CT3 with Fixture Base Table and Cylindrical Probe in compression mode

What's Included?

Instrument with choice of load cell
Texture Loader Software
USB Cable

What's else do I need?

Rotary Base or Fixture Base Table (see below)
At least one probe or test fixture (p60-61)

Optional Accessories

The CT3 has a wide variety of probes, fixtures and jigs which enable it to be very versatile. Brookfield can also custom design a fixture and probe for most applications.

TexturePro CT Software TA-CT-PRO-AY (p59)

Temperature Probe DVP-94Y

Bubble Level TA-LVL

Calibration Weight Set (p59)

Gelatin Bath System for gel conditioning (p57)

Bloom Jar - industry approved TA-GBB-2



TA-RT-KIT

Rotary Base Table



TA-BT-KIT

Fixture Base Table

TexturePro CT Software Optional

COLLECT DATA AND PERFORM DETAILED DATA ANALYSIS WITH REAL-TIME GRAPHIC PLOTTING.

While the CT3 can perform many tests in stand alone mode, use of TexturePro CT Software permits creation of multiple tests and automatic execution without operator involvement.

Easily create custom reports and graphs right from the menu screen.

- Sample identification set-up screen helps new operators quickly get started; test fields outline a variety of parameters
- Intuitive set up for test methods and database file structures in a single window
- Data is captured as a graph and stored in tabular database format
- Advanced data analysis with built-in parameter calculations such as springiness, chewiness, hardness and much more!

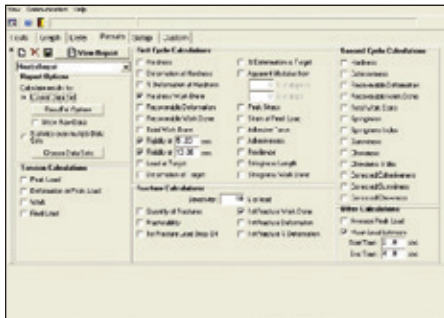

Sample Test Set-up

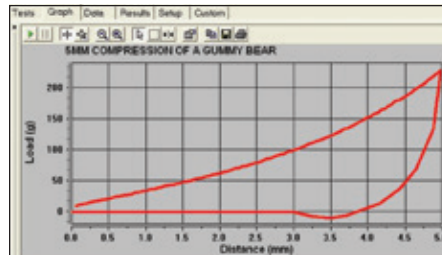

On Screen Live Force Deformation Curve



Tension Mode

provides tensile testing capability

MODEL	Load Range / Resolution*
CT3-100	0-100g/0.01g
CT3-1000	0-1000g/0.10g
CT3-1500	0-1500g/0.20g
CT3-4500	0-4500g/0.50g
CT3-10kg	1-10000g/1.0g
CT3-25kg	1-25000g/2.0g
CT3-50kg	2-50000g/5.0g

g = grams kg = kilograms *Accuracy = $\pm 0.5\%$ Full Scale Range (FSR)

ALL CT3 MODEL SPECIFICATIONS	
Speed:	
Range	0.01-0.1mm/s (increments 0.01mm/s) 0.1 - 10mm/s (increments 0.1mm/s)
Accuracy	$\pm 0.1\%$ of setspeed
Position:	
Range	0-101.6mm
Resolution	0.1mm*
Accuracy	0.1mm

mm = millimeter s = seconds
*Resolution 0.01mm when used with TexturePro CT Software



TA-CW-1500C

Calibration Weight Set contains a combination of certified weights which may be used to confirm the calibration and linearity of each specific load cell.

CT3 Accessories

FOR A WIDE RANGE OF TESTS.

While many CT3 accessories have multiple applications, some are particularly useful for specific industries. The following color coded icons are used here to identify these industries.

- F** FOODS
- C** COSMETICS
- P** PHARMACEUTICALS
- M** MATERIALS & PACKAGING
- D** DEVICES - MECHANICAL

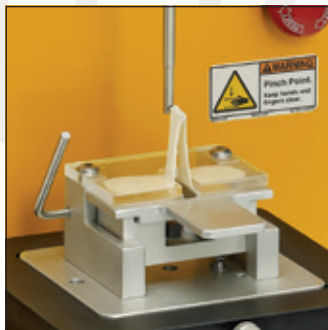

TA-KF F
Kieffer Dough and Gluten Extensibility Fixture quantifies maximum force and distance needed to break sample. Fixture Base Table required.

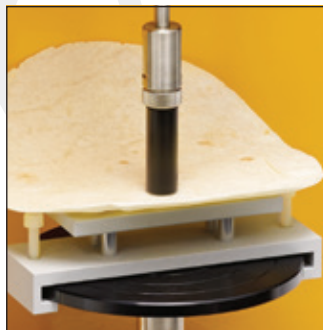

TA-JPA F M
Junior Punch Fixture is for punching through flat samples; 12.7mm max. diameter probe. Hole in fixture is 14mm. Rotary Base Table required.



TA-TPB F
Three Point Bend Fixture is used with TA7 blade from general probe kit. Rotary Base Table required. Small scale version TA-JTPB is available.

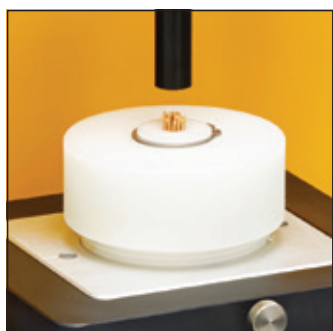

TA-DSJ F
Dough Stickiness Fixture is standard test for measuring dough stickiness; important for processing raw dough. Fixture Base Table required.



TA-DE F
Dough Extensibility Fixture for holding sheet of raw dough or flat bread to measure breaking point of stretched sample. Fixture Base Table required.



TA-CTP F
Compression Top Plate for applying uniform compression forces on samples up to 4x6 inches (10x15cm) Fixture Base Table required.



TA-VBJ F
Volodkevich Bite Jaws for testing bite force of meat products using shear cutting-test. Fixture Base Table required.



TA-PTF F M
Pizza Tensile Fixture quantifies cooked pizza firmness by measuring the tensile force and deformation distance to break sample.



TA-FMBRA F
Standard dough pot set for preparing dough samples and measuring dough firmness.



TA-AACC36 F
AACC spec probe for measuring bread firmness and performing texture profile analysis (TPA). Fixture Base Table required.



TA-SBA F
Shear Blade for products where a cutting-shear test is meaningful: meat, fish, sausage, etc. Fixture Base Table required.

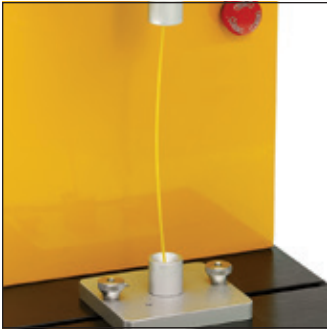

TA-SFF ⓘ

Spaghetti Flexure Fixture quantifies flexure characteristics of uncooked spaghetti and other dry pastas.



TA-OC ⓘ

Ottawa Cell for extruding assorted soft samples, like pasta or diced fruit and vegetables. Fixture Base Table required.



TA-PFS ⓘ

Pasta Firmness and Stickiness Fixture measures the firmness and stickiness of uncooked pasta. Fixture Base Table required.

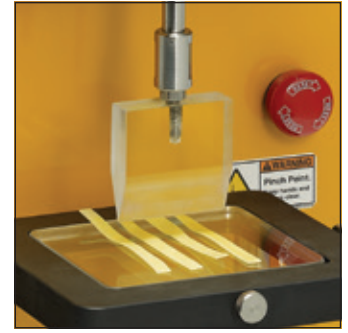

TA-PFS-C ⓘ

Pasta Firmness and Stickiness Fixture measures pasta and like products. Fixture Base Table required.



TA-KSC ⓘ

Kramer Shear Cell for shear-cutting and extrusion test on small fruits and vegetables such as grapes, figs, corn and beans. Fixture Base Table required.



TA-CSF ⓘ

Circular Support Fixture provides support for round samples and retains any potential fluid expressed during the test. Fixture Base Table required.

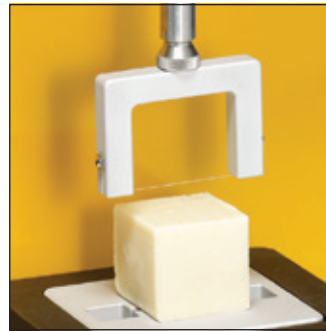

TA-WSP ⓘ

Wire Shear Plate cuts through the sample. Good for products with significant stickiness like cheese and butter. Fixture Base Table required.

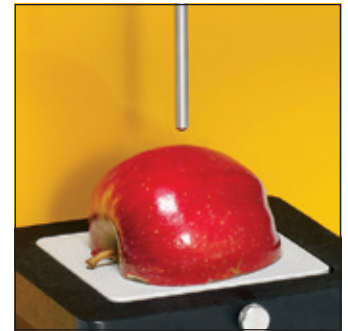

TA-MTP ⓘ

Magness-Taylor Probes for puncture test to measure hardness of fresh fruit and vegetables. Fixture Base Table required.



TA-10 ⓘ

GMIA & GME probe and spec Bloom bottle TA-GBB-2 sold in package of twelve bottles. Rotary Base Table required.



TA-MCF ⓘ

The Multiple Chip Fixture is used for testing the penetration or firmness of multiple chips / french fries. Fixture Base Table required.



TA-CJ ⓘ

Confectionary Fixture for holding candies and similar products for penetration testing. Fixture Base Table required.

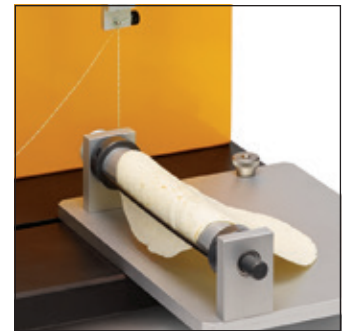

TA-TRF ⓘ

Tortilla Roll Up Fixture evaluates changes in corn tortilla texture per AACC technical paper by measuring the force to roll up a tortilla.

CT3 Accessories

FOR A WIDE RANGE OF TESTS.

While many CT3 accessories have multiple applications, some are particularly useful for specific industries. The following color coded icons are used here to identify these industries.

- F** FOODS
- C** COSMETICS
- P** PHARMACEUTICALS
- M** MATERIALS & PACKAGING
- D** DEVICES - MECHANICAL



TA-CKA **F**

Craft Knife Adapter cuts cleanly into and through material with minimum deformation of the sample.



TA-52 MOHRs

Shear Blade used for cutting tests, especially meat, poultry, fish or similar products. Fixture or rotary base table recommended.



TA-MP **F** **M**

Mesh Probe quantifies the consistency of products such as mayonnaise and yogurt.

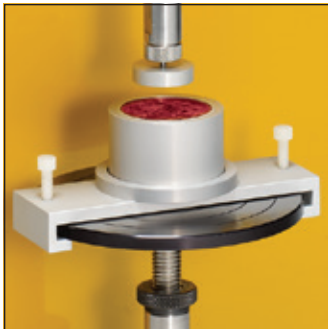

TA-BEC **F** **M**

Back Extrusion Cell for measuring consistency of applesauce, pudding, yogurt and similar products. Rotary Base Table required.

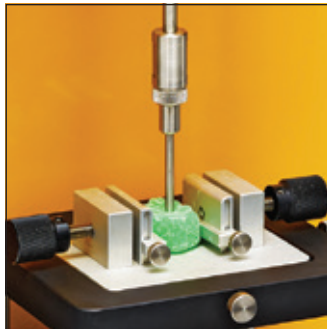

TA-AVJ **F** **M**

Adjustable Vice Fixture for holding small samples for puncture test. Good for jelly beans, gum drops, etc. Rotary Base Table required.



TA-JMPA **F** **P**

Multiple Probe Assembly consisting of nine 3mm probes and base plate designed to hold nine small samples of irregular geometry. Base Table required.



TA-DEC **F** **C** **P**

Dual Extrusion Cell for either forward or back extrusion of fruit puree, pudding, yogurt or similar products. Fixture Base Table required.

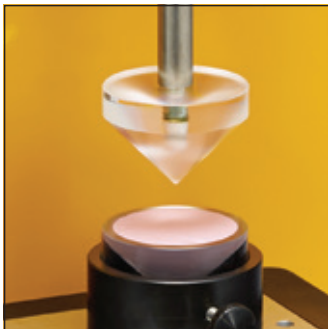

TA-STF **C** **P** **F**

Spread Test Fixture quantifies the spread force of a material. Comes with 1 male cone probe, 5 five samples cups and 1 sample cup holder.



TA-LC **C**

Lipstick Cantilever Test Fixture allows imitative tests on lipstick and similar products to quantify strength of product. Fixture Base Table required.



TA-EP **C** **M**

Eye Pencil Test Fixture measures hardness of cosmetic pencil tips for eye- or lip-lining products and can also be used for artistic type pencil tips. Fixture Base Table required.



TA-TEF **C** **P**

Tube Extrusion Fixture measures the force needed to squeeze cream or paste out of a tube.



TA-MA P

Muco Adhesion Test Fixture Simulates body/temperature conditions and force needed to pull a tablet away from a mucosal surface.



TA-RT P

Raft Tester measures alginate Raft Strength by pulling wire raft hook out of the sample material.



TA-MDI P

Metered Dose Inhaler Fixture measures the push-button force to actuate the inhaler. Fixture Base Table required.



TA-STJ P

Syringe Test Fixture for measuring the force required to push or pull syringe plunger. Important to all syringe markets. Base Table required.



TA-TCA P

Table Coating Adhesion Fixture measures the adhesion force of a tablet coating to a tablet. Fixture Base Table required.



TA-BPS P

Blister Pack Support Fixture is used to measure the force required to remove the tablet from its blister pack. Fixture Base Table required.

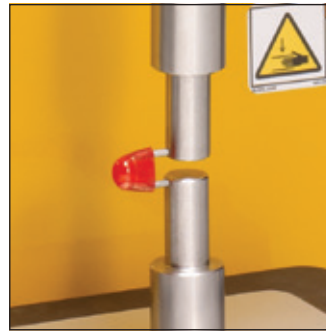

TA-CLT P

Capsule Loop Tensile Test Fixture is used to measure the force required to split one half of a hard gel capsule. Fixture Base Table required.



TA-DGA M P D

Dual Grip Assembly for tensile testing of thin films or integrity of seals for packaging. 10mm and 5mm sizes are available.

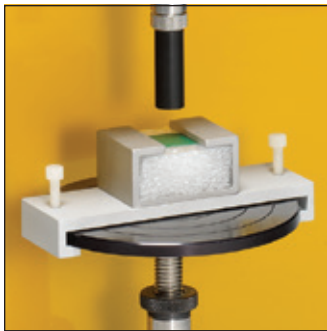

TA-ATT M P

Adhesive Tack Tester for measuring stickiness of pressure sensitive adhesive materials such as tape. Rotary Base Table required.



TA-FSF M P

Film Support Fixture for puncture test to measure strength of fine films. Fixture Base Table required.



TA-LTT M

Loop Tack Test measures the adhesive strength of pressure sensitive tape and stickers according to ASTM D6195.

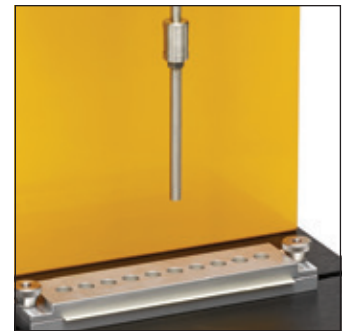

TA-TSF M

Tape Stickiness Fixture measures adhesive force to pull tape off of a surface. Multiple tape samples can be tested simultaneously for average value.

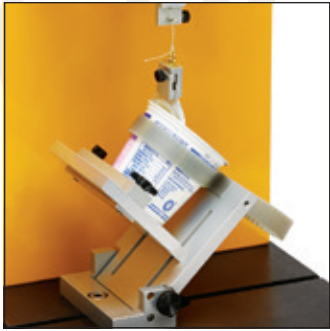

TA-GPJ M

General Peeling Jig measures the adhesive strength needed to remove the lid from a sealed container at 0°, 45°, and 90° angles.

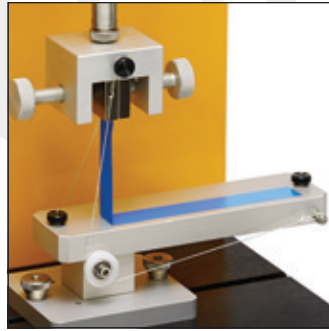

TA-PF90 M

90° Peel Fixture measures the adhesive strength to pull a tape off of a rigid surface using force at a 90° angle.



TA-RCA M D

Roller Cam Accessory grips measure the tensile strength and tear characteristics of material such as polymer films.



TA-SFJ M D

Sliding Friction Jig measures the coefficient of friction for packaging materials according to ASTM D1894.



TA-11 D

Cylindrical probe TA-11 is used to measure the force vs. distance in mechanical springs. TA-11: included in TA-P-KIT2 or as a standalone part.



TA-P-KIT2 F C P M D

Standard Probe Kit is variety of cylindrical (8), cone (3), ball (2), needle (1), knife-edge (1) and wire cutting (1) probes. Complies with BS and AACC.



TA-P-KIT3 F

Curd Probe Kit consists of one each of: 5 mm (TA46), 8 mm (TA47) & 10 mm TA48 curd probes.

Also available:

A variety of cylindrical, cone, ball, needle, knife-edge, and wire cutting probes are also available.

Brookfield can also make custom fixtures and probes for a variety of applications. Please contact Brookfield or an authorized dealer to discuss solutions to your texture and materials testing challenges.



The Brookfield Texture Analysis Lab

TEXTURE ANALYSIS TESTING SERVICES

A variety of texture analysis testing services can be performed at all Brookfield locations (USA, UK, Germany, China and India). Most services are performed free-of-charge.

TEST AND RECOMMEND

A simple evaluation designed to help determine the appropriate CT3 equipment for your application.

SAMPLE PROFILING

Analysis testing to determine specific properties of your sample.

DISPUTE RESOLUTION

Analysis testing for mediating a resolution between producers and/or suppliers in cases where each has different results for the same material.

MULTIPLE SAMPLE TEST

Expands the capability of your laboratory by utilizing Brookfield's services to accomplish testing work on a timely basis.

TEXTURE APPLICATIONS

The CT3 Texture Analyzer is used to test many different types of materials. General categories are identified and examples from each are presented.



TA-DEC
Dual Extrusion Cell

COSMETICS

Physical consistency of cosmetic creams is successfully characterized by an extrusion test. Lipstick firmness is confirmed with a bending test.

SOME RECOMMENDED CT3 ACCESSORIES

TA-DEC TA-EP TA-LC
TA-TEF



TA-DGA
Dual Grip Assembly
5mm size shown

PACKAGING

Tensile test on package seals determines how hard it will be to rip open. The force required to remove capsules from blister packaging is measured with a finger probe in compression.

SOME RECOMMENDED CT3 ACCESSORIES

TA-ATT TA-AVJ TA-BEC
TA-DGA TA-FSF TA-GPJ
TA-JPA TA-LTT TA-PF90
TA-PTF TA-SFJ TA-TSF



TA-NTF
Noodle Tensile Fixture

FOODS

Snap test on cracker gives clear indication of freshness. Cutting test on cheese cube verifies strength of sample and whether it will crumble.

SOME RECOMMENDED CT3 ACCESSORIES

TA-DE TA-DSJ TA-FMBRA
TA-JPA TA-KF TA-MP
TA-PFS TA-PFS-C TA-PTF
TA-SBA TA-SFF TA-TPB
TA-VBJ TA-WSP *and many more*



TA-TEF
Tube Extrusion Fixture

PERSONAL CARE PRODUCTS

The squeezing force to extrude creams and pastes is quantified using a support fixture to hold the tube in place while pressing down with a finger-shaped blade.

RECOMMENDED CT3 ACCESSORY

TA-TEF



TA-10
GMIA & GME probe
and spec Bloom bottle

GELATIN

Universal method for establishing the value of gelatin is via the Bloom Test which measures the physical strength of the sample using a cylinder probe.

RECOMMENDED CT3 ACCESSORY

TA-10



TA-BLS
Bilayer Shear
Test Fixture

PHARMACEUTICALS

Adhesive property of tablet coatings is also determined using a tension test. The burst strength of capsule shells is directly measured using a tension test to rip the capsule apart.

SOME RECOMMENDED CT3 ACCESSORIES

TA-BPS TA-DEC TA-FSF
TA-MA TA-MDI TA-RH
TA-STF TA-STJ TA-TCA
TA-TEF



TA-11
Spring rate test
measures force vs
distance of springs

MECHANICAL DEVICES

Brookfield has done extensive testing with the CT3 on various mechanical components over the last year. We have solutions for o-ring force vs. compression distance, key pad button actuation force, crimping force test for wire in clamps, life cycle testing for switches and actuators and much more. Call us for details.

RECOMMENDED CT3 ACCESSORY

TA-11 TA-DGA TA-RCA
TA-SFJ TA-P-KIT2

powder testers



flow

What is powder analysis?



Particulate materials constitute a large group of solids that can range in size from sub micron particles to large rocks and minerals. Brookfield's Powder Flow Tester measures the flow behavior of bulk solid materials that have a top particle size of 2mm. At least 90% of the sample should consist of particles less than 1mm in diameter. In many instances, powders with larger particles can still be characterized effectively by sieving the material at 1mm and testing the fines (the fines control the flow properties of a material with a wide size range). The generic term used by Brookfield to name these materials is "powder", therefore the name of our instrument is "Powder Flow Tester".

Unlike liquids which, under the influence of gravity, tend to have a horizontal surface, powders exhibit a structure, due to internal friction and cohesion, which allows them to form piles with angles relative to the surface on which they are placed. At ambient conditions, powders do not change flow behavior when subjected to variable shear rates, whereas most liquids do. However, pressure controls the strength of a powder (i.e., increases the resistance to flow) whereas a liquid will show limited change in rheology under pressure. In other words, the consequence of subjecting a powder to a compressive force is that the powder will flow less easily; the relationship between the compressive stress applied to consolidate the powder and the strength it obtains is the measurement of the powder flowability, or its "Flow Function".

There is a need throughout industry to characterize powder flow properties and flow behavior. The Brookfield Model PFT Powder Flow Tester is a precision instrument of robust design that satisfies this need and more.

What are the industrial issues with powders?

The classic problem with powders is their failure to discharge reliably from bins, hoppers, silos, etc., and poor or unpredictable flow in feeders, dosing machines, packing machines, etc. This causes unwanted interruptions in the production process, leading at times to complete plant shutdown in order to correct the flow restrictions and stoppages. It also leads to variations in pack weight, mixture, performance and sensory properties of powder products.

Quality Control Departments are constantly dealing with raw materials in powder form, which come from multiple suppliers. The variability in particle size and distribution, moisture content, and basic ingredients requires a battery of incoming inspection tests, none of which assure that proper flow will take place when loaded into the plant equipment. The Brookfield Powder Flow Tester is a single-solution instrument which can resolve this uncertainty.

R&D Departments are constantly adjusting formulations of powder products to satisfy customer demand for improved properties: better coating action for paints, enhanced taste for spices, rapid dissolving of chemicals when put into solution. New formulations do not necessarily have the same flow properties, thereby leading to production problems when the process is scaled up to high volume. The Brookfield Powder Flow Tester can predict those problems so they can be prevented.

How can flow problems with powders be eliminated?

There is a proven scientific method, called the "Flow Function test", which can analyze powders for flow behavior. ASTM D6128 describes this procedure for compressing and shearing powder samples in a defined annular shear cell, using a well-defined methodology established years ago.

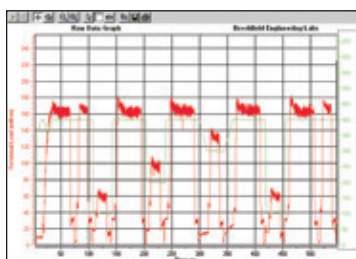

Test algorithm for powder flow analysis requires compression of the sample contained in an annular cell to a defined axial load followed by torsional shearing. Raw data output shows torsional load values in red. Compression of sample is shown as axial load values in green.

The resulting data produces a “Flow Function”, much like what is obtained for liquids when testing with a viscometer to create a “flow curve”.

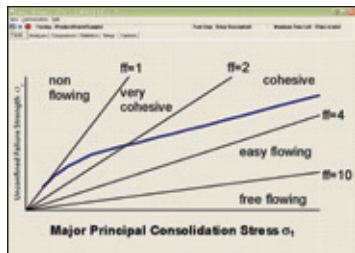

Flow Function for powder sample shows “non-flowing” to “very cohesive” behavior at low consolidation stresses and “cohesive” behavior at higher consolidation stresses.

Analysis of the “Flow Function” leads to calculation of the critical outlet dimensions of feeders, hoppers, etc., through which the powder will flow. Comparing the “Flow Function”, or these critical dimensions, allows powders to be benchmarked, ranked and compared against one another for flowability. The dimensions can also be used to determine whether a particular powder will flow through an existing plant or process, or to determine what the geometry should be if purchasing new solids handling equipment.

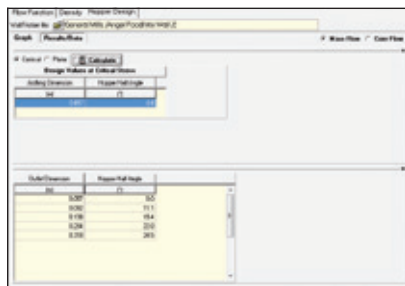

Data output from Flow Function test provides “Arching Dimension” and “Rathole” diameter. Data output from additional Wall Friction test provides “Hopper Half Angle”.

Although ASTM D6128 has existed for many years, the instrumentation used to accomplish the test has been expensive to purchase, requires an experienced operator, and may need a technical expert to interpret the results.

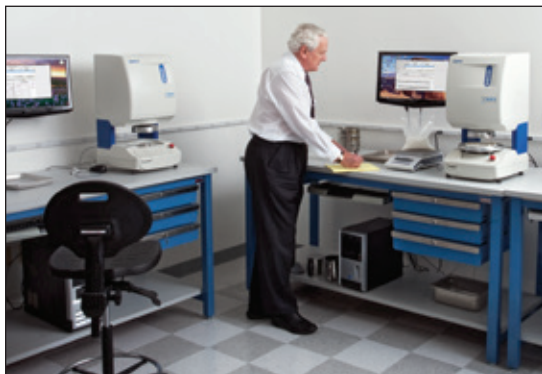

The Brookfield Powder Testing Lab

Why Choose Brookfield?

Brookfield has over 75 years experience in providing reliable, low cost viscosity and texture measurement instruments while offering high quality product support. We are now using this recipe for success to expand our line of physical testing products to include the Powder Flow Tester.

THE NEW BROOKFIELD POWDER FLOW TESTER IS THE SIMPLE ANSWER TO INDUSTRY NEEDS:

The purchase price is a small fraction of current devices on the market.

A competent lab technician can run tests and collect data within minutes, eliminating the need for a powder specialist.

The automated analysis provided by the Powder Flow Pro software calculates various properties of the powder, including the critical dimensions for reliable powder flow out of the hoppers, feeders, bins and silos.

The Wolfson Center for Bulk Solids Handling Technology at the University of Greenwich, England, has worked closely with Brookfield to design the Powder Flow Tester, thereby, ensuring its suitability for practical industrial use.

Applications

R&D, Incoming Materials Inspection, New Product Formulation, Quality Control, Process Plant Design

Adhesives	Energy:	Gunpowder/ Ammunition
Cosmetics	Biomass	Healthcare Products:
Chemicals	Coal	Tablets
Construction:	Fluxes	Minerals
Cement	Food:	Personal Care Products:
Fly Ash	Beverages	Talcom Powder
Gypsum	Biscuits	Pharmaceuticals
Hydrated Lime	Cereal	Starch
Detergents	Chocolate	
Equipment Manufacturing:	Cocoa/Milk Powder	
Silos	Cookies	
Bins	Crackers	
Feeders	Flavorings	
Hoppers	Flour	
	Seasonings	
	Spices	

Properties Measured

Flow function
relation between consolidation stress
and powder strength
Angle of internal friction
Angle of wall friction
Cohesive strength

Bulk density
Arching dimension
Rat-hole diameter
Normalized flow function

PFT™ Powder Flow Tester

...affordable testing for powder characterization

The PFT Powder Flow Tester brings quick and easy analysis of powder flow behavior in industrial processing equipment. Evaluate powder discharge from storage containers. Use as QC check for incoming materials. Rapidly characterize new formulations for flowability and adjust composition to match flow behavior of established products.

Choice of Test Options:

- Flow Function
- Time Consolidated Test with Flow Function
- Wall Friction
- Bulk Density

Choice of Flow Function Tests:

- Demo (8 minutes)
- Standard (38 minutes)
- Time Consolidation (user-defined)

Real Time Clock Displays:

- Test Step
- Remaining Time to Completion

Shearing Algorithm Captures:

- Peak Stress Value
- Subsequent Stable Stress Value
- Recognizes "Slip Stick" Materials

Data Output:

- Flow Index for Powder Flowability
- Arching Dimension (Index)
- Rat-hole Diameter
- Hopper Half Angle
- Gravity Chute Angle (Wall Friction Angle)
- Bulk Density Curve

Compact design with small footprint
Tester fits conveniently on workbench
Depth: 15inches / 38cm
Width: 14inches / 36cm
Height: 27inches / 69cm



Developed in association with
The Wolfson Centre
for Bulk Solids Handling Technology
at the University of Greenwich, England.

What's Included?

Instrument

Powder Flow Pro Software with USB Cable

Choose one or both:

- Standard Volume Accessory Kit
230cc Trough & 33cc Vane Lid
- Small Volume Accessory Kit
38cc Trough & 5cc Vane Lid

Wall Friction Lid
304 s/s simulated 2B finish

Outer Catch Tray

Inner Catch Tray with Scraper Tool

Powder Scoop

Cleaning Brush

Optional Accessories

Wall Friction Lids
in Mild Steel 22-28RA, Tivar 88 or special order

Temperature Probe

Humidity Sensor

Sieve Kit

Standard or Small Volume

Carrying Case for easy transport

Sand Castle Demonstration Kit

Powder Flow Demonstration Kit



Small Volume Vane Lid
.795-13.252 kPa

Standard Volume Vane Lid
.289-4.819 kPa

Powder Flow Pro Software Included

Operation and control of the Powder Flow Tester is accomplished with Powder Flow Pro Software.



Main screen provides choice of basic tests:

- Flow Function
- Wall Friction
- Time Consolidated Flow Function
- Bulk Density

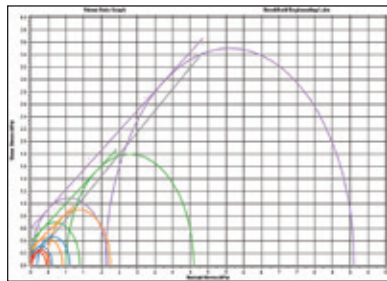

Stress data output screen captures "normal stress" and "shear stress" values and plots data in graphical format (calculates Mohr Circle Failure Loci).

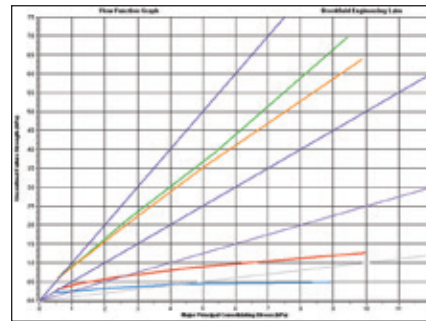

Flow Function test produces graphs of powder flow behavior which show:

- Unconfined Failure Strength vs. Major Principal Consolidating Stress
- Arching Dimension vs. Principal Consolidation Stress
- Rat-hole Diameter vs. Powder Fill Level
- Arching Dimension vs. Hopper Half Angle

PFT POWDER FLOW TESTER SPECIFICATIONS

Load for Vertical Axis Compression:	7 kg — Accuracy $\pm 0.6\%$ FSR
Axial Speeds:	0.1mm/second up to 5mm/second
Distance:	Accuracy ± 0.3 mm
Torque:	± 7.0 N•m — Accuracy $\pm 1.2\%$ FSR
Trough Rotational Speeds:	1 revolution/hour (RPH) up to 5 RPH
Temperature Sensing:	-20°C to 120°C*
Humidity Sensing:	10% to 95% RH $\pm 5\%$ †
Dimensions (wxdxh):	(cm) 36.2 x 39.7 x 67.6 (in) 14 ¹ / ₄ x 15 ⁵ / ₈ x 26 ⁵ / ₈
Weight:	34 kg (75 lb)

* Requires Part No. DVP-94Y

† Requires Part No. PFT-607Y

MINIMUM COMPUTER SPECIFICATIONS FOR POWDER FLOW PRO SOFTWARE

2GHz processor with 1 GB of RAM and 30 MB hard drive space available
 1024x768 video resolution with 128 MB of graphics memory
 Windows XP, Vista or Windows 7 (32 and 64 bit) with one USB or RS-232 port



Close-up View of Vane Lid used for Flow Function Test.



Close-up View of Wall Friction Lid for wall friction test and density test

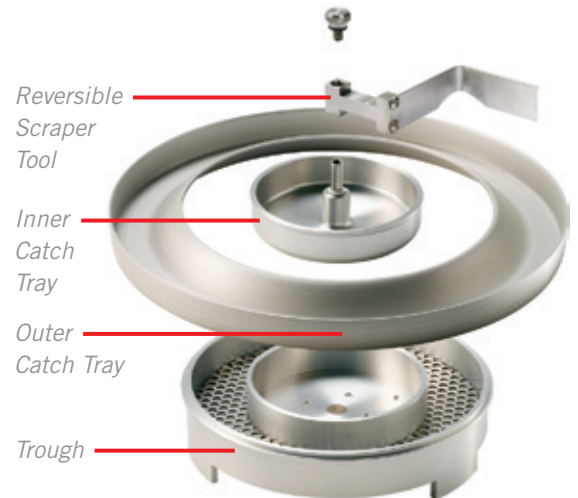

Outer and Inner Catch Trays with Scrapper Tool for Sample Preparation in Trough

Testing Service

for powder applications

To assist you in the evaluation of your powder for flow behavior, Brookfield offers a testing service prior to purchase. Provide Brookfield with samples of your product to obtain a complete test report. Data is presented in both graphical and tabular format for easy analysis and interpretation. The following example shows the report format and type of information that is presented. In the concluding section, calculations for critical arching dimension, rat-hole diameter and hopper half angle assess the potential for stoppages due to the powder flow behavior or equipment limitations.

Customer Test Report

DATA COLLECTED BY: BROOKFIELD POWDER FLOW TESTER

STANDARD TESTS

This report follows four samples sent to our lab for evaluation. The specific graph for each sample is color coded for easy identification. Up to eight data sets can be shown on the same graph.

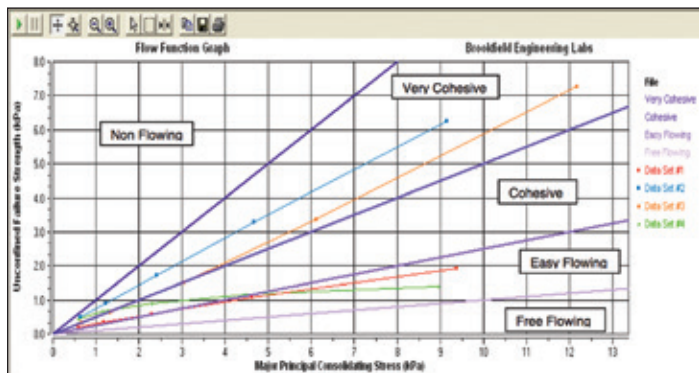

Flow Function Graph (230cc Trough)

This flow function graph illustrates the flowability of the samples over different consolidating stresses. The x-axis parameter is the consolidating stress used to compress the sample; the y-axis parameter is the strength of the powder. **Sample (Data Set) #2** is the most cohesive material of all, falling into the very cohesive range throughout all consolidating stresses. **Sample (Data Set) #3** powder also falls into this category. **Sample (Data Set) #4** is very cohesive at low consolidating stresses (below 1.5 kPa), cohesive at medium stresses (1.5 - 4.5 kPa), and easy flowing at high consolidating stresses (above 4.5 kPa). **Sample (Data Set) #1** material is cohesive at consolidating stresses from 0 – 4.0 kPa, and easy flowing at consolidating stresses above 4 kPa. Sample 2 clearly exhibits the greatest difficulty for reliable flow behavior.

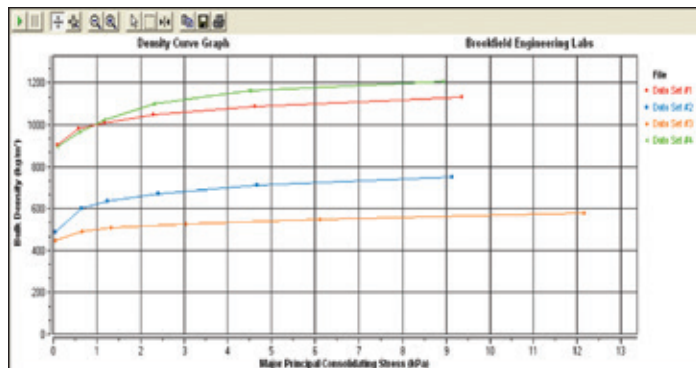

Bulk Density Graph (230cc Trough)

This bulk density graph illustrates the density of the samples over different consolidating stresses. **Samples #1 and #4** have almost identical loose fill densities of 900 kg/m³. At 9 kPa of consolidating stress, the density of **Sample #1** rises to 1150 kg/m³ and **Sample #4** rises to 1200 kg/m³. **Samples #2 and #3** have similar loose fill densities ranging from 450-500 kg/m³. At 9 kPa of consolidating stress, the density of **Sample #2** rises to 770 kg/m³ and **Sample #3** rises to 590 kg/m³ at 12 kPa of consolidating stress. In general a free flowing powder shows a relatively small change in density with more consolidating stress, while a cohesive powder shows a large change in density.

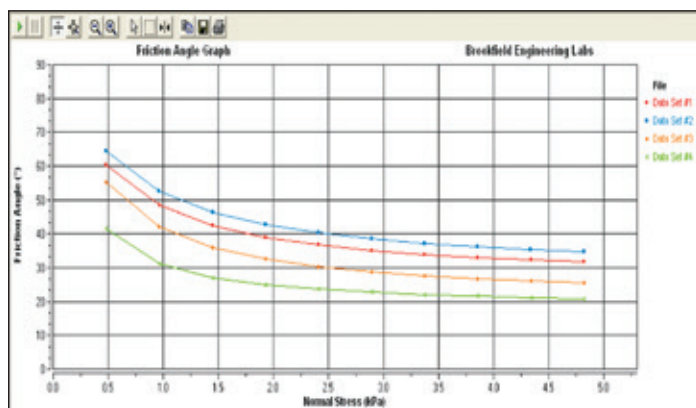

Wall Friction Angle Graph (230cc Trough)

This graph illustrates the angles of wall friction for each powder over different consolidating stresses. At low normal stress (0.5 kPa) all materials had extremely high wall friction angles ranging from 40° to 65°. At a higher normal stress (4.75 kPa), the wall friction angles dropped to a range of 20° to 35°. Wall friction angles above 30° are considered very high and below 10° are very minimal. This indicates that **Sample #2**, and perhaps **Sample #1**, will have difficulty with reliable flow on the hopper wall surface.

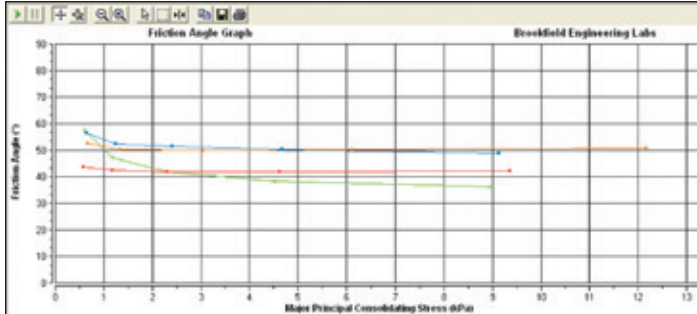

Internal Friction Angle Graph (230cc Trough)

This graph illustrates the angles of internal friction at different levels of normal stress. The angle of internal friction is a measure of the friction between the powder particles as they slide against each other. **Sample #1** and **Sample #4** have the lowest angles of internal friction and will therefore flow more readily than the other two powders. The angle of internal friction for **Sample #2** and **Sample #3** is approximately 50° which is relatively high and indicative of potential flow problems.

Types of Flow Patterns

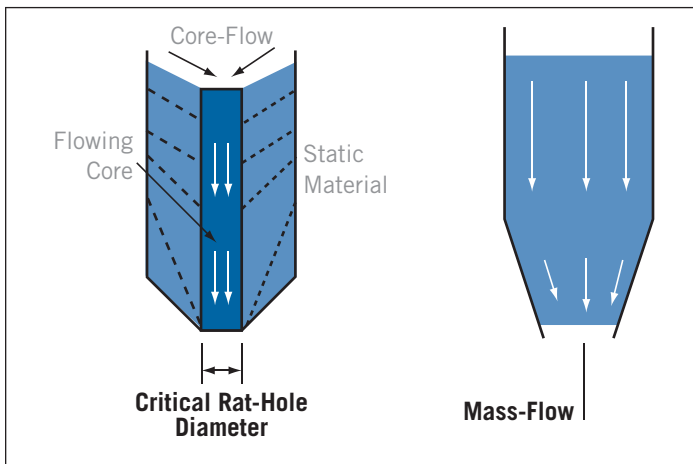

TIME CONSOLIDATION TEST

Additional testing on these samples would investigate the effect of time consolidation, which addresses how powders increase their internal strength when left in bins/hoppers for longer than planned.

Test duration could be as short as 30 minutes or as long as several days. The former represents a temporary work stoppage, the latter an extended plant shutdown. Long term time consolidation tests also predict strength buildup in powders stacked on pallets in storage or in transport over long distance.

Summary

CRITICAL ARCHING DIMENSIONS

SAMPLE (DATA SET) #1	21 mm (0.85 in)
SAMPLE (DATA SET) #2	480 mm (19 in)
SAMPLE (DATA SET) #3	80 mm (3.1 in)
SAMPLE (DATA SET) #4	100 mm (3.9 in)

The critical arching dimension is a conservative calculation of the powder's potential in mass flow behavior to build a stable bridge over the hopper outlet, thereby restricting flow. The arching values above indicate that the hopper opening must be greater than 480 mm (18.9 in) to ensure reliable discharge of all powders. The critical arching dimension for **Sample #2** is much greater than the other three powders due to its very cohesive and "sticky" nature, thereby having a much greater tendency to form a stable arch. This calculation also applies to the design of any conveyance device directly downstream of the hopper, such as the spacing between flutes on a screw feeder.

The Powder Flow Tester can also be used to calculate the critical rat-hole dimension which relates to a behavioral problem that may occur under core flow conditions. This calculation requires user input on bin shape, cross section dimension(s), and hopper type (wedge, conical). When this information is provided, the Powder Flow Pro software is able to automatically calculate the rat-hole diameter, as well as the hopper half angle.

Types of Flow Obstructions

RAT-HOLE

$$D_{RH} = \frac{G(\theta) \times \sigma_{crit}}{\rho_B \times g}$$

(where $G(\theta) = 0.7771 \times e^{0.0381\theta}$)

ARCHING DIMENSIONS

Conical Hopper: $D_c = \frac{2 \times \sigma_c \times 1000}{\rho_B \times g}$

Plane Hopper: $D_p = \frac{\sigma_c \times 1000}{\rho_B \times g}$

(where $3dp < L$)

The customer also receives the detailed data reports in tabular format which record all measurement values shown in the graphs.

In some cases, the customer chooses to request additional testing services on a fee basis. This may involve more testing on existing samples or new samples that the customer wishes to evaluate.

SSB: Starch Applications

recommended viscometer choices



*DV2TRV Viscometer (p10)
or DV3TRV Rheometer (p8)
Ball Bearing Suspension (p50)
TC-112P Programmable Water Bath
Small Sample Adapter (p38)
SC4-21 Spindle
SC4-13RPY Sample Chamber
w/RTD probe (p48)*

The SSB (Starch System Brookfield) is designed to monitor the viscosity of industrial starches during automated quick-cook (gelatinization) and fast cool-down of starch samples.

FEATURES & BENEFITS

Fast, reproducible results means production adjustments can be made immediately.

Automated, easy-to-compare test results using Optional Software

Programmable temperature control +35°C to +95°C

Chocolate Applications

recommended viscometer choices



*DV2THA Viscometer (p10)
or DV3THA Rheometer (p8)
Ball Bearing Suspension (p50)
TC-150 Water Bath (p35)
Small Sample Adapter (p38)
SC4-27 Spindle (p48)
SC4-13RPY Sample Chamber
w/RTD probe (p48)*

Measuring chocolate viscosity is important to the confectioner in order to help optimize chocolate flow properties in a melted condition for various mixing and coating applications.

FEATURES & BENEFITS

Determines Casson yield and Plastic Viscosity

Conforms to NCA and Bureau of the Technical Committee Office Internationale du Cacao et du Chocolat.

Control of melting temperatures assuring reproducible comparisons

Easy to clean, easy to operate

Paints, Coatings & Ink Applications

recommended viscometer choices



*DV2T Viscometer
not shown (p10)*

*KU-2
Viscometer (p31)*



*CAP 2000+
Viscometer (p20)*

Brookfield has viscometers that have been designed specifically for use in Paint and Coating applications. Whether your requirement is to measure in Krebs units with the KU-2, simulate flow behavior at high shear with the CAP, measure new formulations with DV2T.

FEATURES & BENEFITS

Easy to clean, easy to operate

Instant results, no calculations means fewer errors

Ensure coating quality

Long term reliable performance

Economically priced

Asphalt Applications

recommended viscometer choices



*DV2TRV Viscometer (p10)
or DV3TRV Rheometer (p8)
Thermosel (p36)
SC4-27 Spindle (p47)
Programmable Controller (p36)*

Specific test methods for measuring the viscosity of highway asphalt “binders” at mixing and compacting temperatures using Brookfield’s Thermosel System have been defined by SHRP, the Strategic Highway Research Program, sponsored by the US Government..

FEATURES & BENEFITS

Adheres to ASTM Spec D4402

Ensures asphalt pumpability

Provides variable temperature and shear rate capability for complete viscosity profiles

Personal Care Products Applications

recommended instrument choices



*RST-CPS Touch
Rheometer (p25)*



*CT3 Texture
Analyzer (p58)
w/Extrusion Cell*

Shampoos and lotions need to flow easily yet retain sufficient thickness. Viscosity analysis and temperature profiling are important QC tools to use. The R/S-CPS Rheometer is important for comprehensive data analysis.

Viscosity FEATURES & BENEFITS

Small sample volume & rapid temperature control

Texture FEATURES & BENEFITS

The CT3 Texture Analyzer can extrude the semi-solid gel of cream or ointment in a controlled manner, revealing the yield stress and flow characteristics of the product.

Electronics Paste Applications

recommended viscometer choices



*DV2THB
Viscometer
(p10)
Spiral Adapter
(p44)
Ball Bearing
Suspension
(p50)*

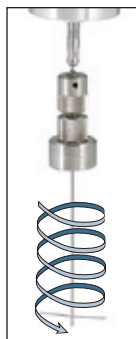

*RV DV-I Prime
Viscometer (p12)
Model D Helipath
Stand (p42)*

FEATURES & BENEFITS

The rheological properties of solder paste affect behavior during application to electronic assemblies. This includes dispensing operations and flow characteristics during screen and stencil printing. The Brookfield RVDV-I Prime Viscometer with Helipath Stand and T-bar spindle provides single point viscosity measurement for QC control. The Brookfield DV2THB Viscometer with Spiral Adapter offers an automated test method for total flow curve evaluation.

Spindle can be inserted directly into paste container

Methods comply with IPC test specifications

Brookfield In-line Systems also available - call for details

Pharmaceutical Applications

recommended instrument choices



*RST-CPS
Touch
Rheometer
(p25)*



*CT3 Texture
Analyzer (p58)
w/Syringe Test
Fixture*

Viscosity FEATURES & BENEFITS

Most ointments need to be sufficiently thick when standing to prevent them from oozing away from the intended area of use. They also need to flow easily when applied (known as shear thinning behavior). The R/S-CPS Rheometer measures high viscosity at near zero shear rate to determine yield stress values.

Texture FEATURES & BENEFITS

The hardness of a tablet, the dissolution of a tablet or the strength of a gel capsule will have an effect on drug release rate in the body. The CT3 accommodates variable geometries while maximizing the value of data obtained.

Petroleum Applications

recommended instrument choices



PVS Rheometer (p22)



*DV2TLV
Viscometer (p10)*

PVS Rheometer FEATURES & BENEFITS

Fracturing fluids, drilling muds, cements and oil/water emulsions are examples of materials easily analyzed.

Viscosity measurements under pressure & at elevated temperature

Automate standard test procedures

DV2TLV Viscometer FEATURES & BENEFITS

Ensures a quick and easy way to check fracturing fluid viscosity. Special cylindrical spindles provides capability for Low Shear Rate Viscosity Test (LSRV).

Sauces & Dressings Applications

recommended instrument choices



*RVDV-I Prime
Viscometer (p12)
Model D Helipath
Stand (p42)*



*CT3 Texture
Analyzer (p58)
w/Extrusion Cell*

Lab FEATURES & BENEFITS

Multiple instrument/spindle choices to suit most applications

Economically priced to meet low budget requirements

Quick, single point viscosity tests often meet the objective

Texture FEATURES & BENEFITS

Quick, easy method to quantify flow behavior out of the bottle or tube using an Extrusion Cell Fixture

Rugged, easy-to-use instrument for use on the production floor

Use with application software for new formulation testing

Construction Materials

recommended instrument choices



*RST-SST Touch
Rheometer (p27)
Vane Spindle (p47)*



*DV3T
Rheometer (p8)
Vane Spindle (p8)*

The construction industry manufactures a wide range of materials with medium to high viscosity. Methods and spindles are available that can handle materials ranging from gypsum-based joint compounds, cements, concretes, mortars and grouts to various clay mixtures.

FEATURES & BENEFITS

Multiple spindle types can be used with the same instrument minimizing investment cost

Yield stress test gives more information than traditional “slump test”

Flow curves are quickly generated to show complete shear thinning behavior for consistent quality

Dairy Products Applications

recommended instrument choices



*RST-SST Touch
Rheometer (p27)*



*CT3 Texture
Analyzer (p58)*

The dairy industry has a broad range of products requiring viscosity and texture measurement. Brookfield instruments ensure consistent quality, flow/spread behavior, and mouth-feel.

Lab FEATURES & BENEFITS

Accommodates homogenous liquids as well as heterogeneous mixtures with particles

Guarantees customer satisfaction because quality is repeatable

Texture FEATURES & BENEFITS

Simple, easy-to-implement test methods

Wide choice of probes to simulate customer experience in handling/consumption of product

Adhesives Applications

recommended viscometer choices



*DV2TRV/HB
Viscometer (p10)
Thermosel (p36)
Programmable
Controller (p36)*



*DV3THBCP
Rheometer (p8)*

Adhesives can vary significantly in viscosity. Product viscosity can be modest with easy flow capability to paste-like consistency, requiring high force to apply to a substrate. Choosing the proper test method is critical.

Lab FEATURES & BENEFITS

Multiple choices for “best-fit” instrument and spindle

Guarantees consistent end product from batch-to-batch

Small sample size (<2mL) for high value products

Process FEATURES & BENEFITS

Continuous control of viscosity when applying to substrate

Ensures economic use of adhesives in continuous operations

The background is a vibrant yellow color, overlaid with a dynamic splash of water. The water is captured in mid-air, creating intricate patterns of droplets, bubbles, and thin, flowing streams. The lighting highlights the texture of the water, giving it a sense of movement and depth. The overall composition is energetic and visually striking.

process viscome

A high-speed photograph of a water splash against a vibrant yellow background. The water is captured in mid-air, creating a complex, multi-layered structure with numerous small droplets and larger, more defined shapes. The lighting highlights the texture and movement of the water. The word "eters" is overlaid in a clean, white, sans-serif font on the left side of the image.

eters

Why measure viscosity in-line?

Why Measure Viscosity In-Line?

Practical application of viscosity measurement data often leads to the need for in-process control of viscosity. The installation of viscosity control equipment on a process can provide a level of control achievable by no other means. Variations in viscosity are detected and corrected instantly before they can negatively affect product quality. Real time viscosity control can reduce downtime and material waste by ensuring that the process is operating within its specified viscosity parameters. In many cases, the savings from increased efficiency can pay back the cost of the viscometer in only a few months.

Why Choose Brookfield?

Brookfield builds its Process Control Viscometers to the same high standards of performance and value as its Laboratory Viscometers. Particular attention has been devoted to making these instruments rugged and easy to maintain for long service in demanding industrial environments.



AST-100

Advanced sensor technology for direct in-line viscosity measurement (p82)



TT-100

For in-line system applications requiring pipeline mounting (p82)



PV-100

In-tank, Probe Viscometer for pressurized systems (p83)



Viscosel

For systems open to the atmosphere (p83)



KV-100

Capillary Viscometer for open atmospheres (p83)

Questions to Consider

1. What is the viscosity range of your material?
2. Is your material Newtonian, Dilatant, Non-Newtonian, Thixotropic or Plastic?
3. What is the minimum, maximum and average pressure requirement of your application?
4. What is the minimum, maximum and average temperature of your application?
5. What is the minimum, maximum and average flow rate of your application?
6. Where in production would you like the viscometer: in-line, on the top of the tank or on the side of the tank?
7. What electrical code requirements do you have:
 - NEMA 1 (general purpose—indoor)
 - NEMA 4 (watertight/dust tight for indoor/outdoor use)
 - NEMA 7 (explosion proof—Class 1, Div. 1&2, Group D)
 - ATEX (explosion proof—Code: EE x d 11B T6)

The above parameters may eliminate some of the instrument models because, for example, the viscosity is higher than the range of the instrument or outside of the pressure rating of the instrument. In many cases, more than one instrument may be applicable.

Please allow us to assist you in choosing the best viscosity control system for your application.

In-Line Viscometers Provide Automatic Control of Process Fluid Viscosity

There are many ways that viscosity can be measured, such as capillary, vibration and rotational. These methods have different benefits and may work well for process monitoring or control but will likely not give the same values as laboratory or analytical methods. In general, laboratories require a more scientifically accurate measurement, while process control requires a stable, repeatable signal. Process measurements are made both in-line and off-line. A bench-top viscometer has often been used for off-line measurements wherein a sample of the process fluid is drawn and tested under controlled conditions (temperature, shear history, shear rate, etc.). In-line viscometers are immersed in the process stream. They measure and control continuously under process conditions helping to maintain a consistent quality product. The demands of these two environments are different, and it is unlikely the same equipment can be used for both or that the exact same results will be generated. However, if done properly, the results will follow the same trend and can be correlated to the bench top, making in-line measurement useful for ensuring consistent production quality.

WHAT ARE THE BENEFITS TO BRINGING YOUR MEASUREMENT IN-LINE?

In-line measurements give real-time, continuous readings of the fluid's viscosity during processing and consequently provide a means to automate the modification and viscosity control of the process fluid. While it is difficult to control all the factors present in the process that affect the fluids' viscosity (such as temperature, air bubbles, shear history, turbulence, pressure variations, etc.), if these factors are kept relatively constant, then good control can be achieved.

WHAT EFFICIENCIES ARE GAINED BY MEASURING IN-LINE?

Automatic control of the process fluid viscosity insures consistent product all the time and reduces or eliminates human errors and expensive sample testing. Also, it provides for a complete record of how the process varied over a span of time, instead of at just one point in time.

WHAT ARE THE TOP THREE FACTORS TO CONSIDER WITH CHANGING YOUR MEASUREMENT PROCESS?

For process measurements, the critical factors are stability, repeatability, and sensitivity to changes in viscosity. In the laboratory or for analysis environment controls (e.g. temperature, flow, sedimentation, air, etc.) and scientific measurements (controlled shear, geometry measurements and sample preparation) must also be included.

HOW DOES MONITORING THE VISCOSITY AFFECT PRODUCT QUALITY?

Most products are formulated to flow or spread in a controlled manner. Monitoring viscosity at critical shear points ensures that the product will act the same way every time the customer uses it. This is the most tangible indicator of quality.

Manual Viscosity Control

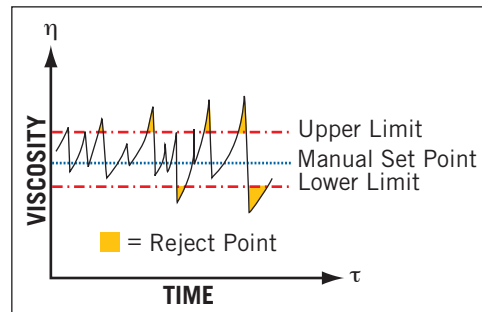

In-Line Viscosity Control

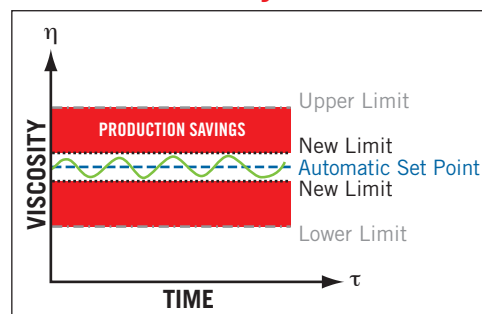

**For more information,
call or visit our website
to request your copy of our
Process Viscometers Catalog**

AST-100™ Viscosity Controller

Advanced Sensor Technology for simple, direct in-line viscosity measurement

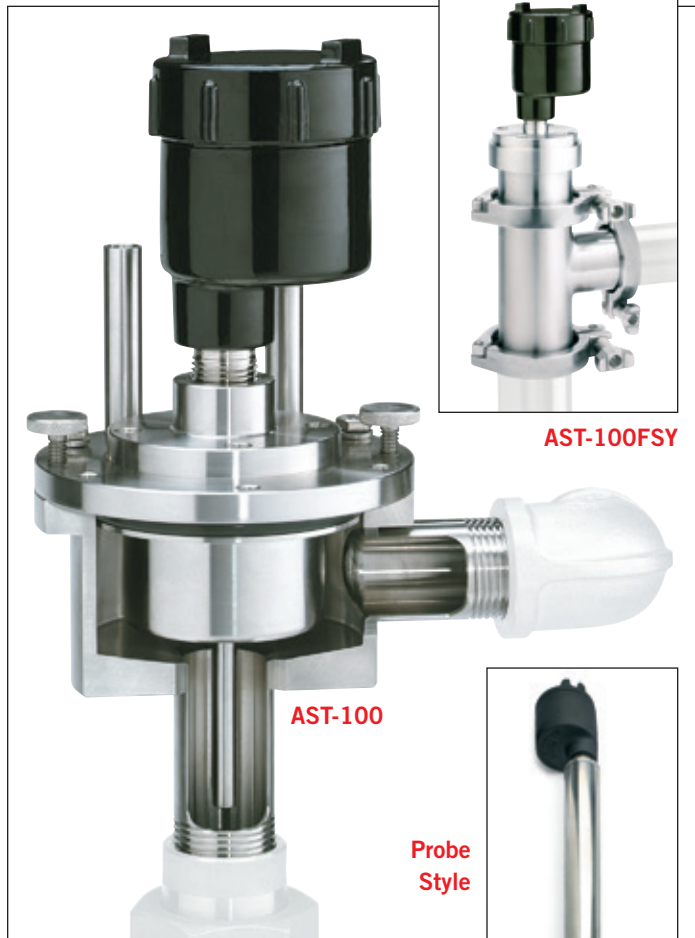

What's Available?

Vibrating Element Viscosity Sensor in Nema 4, Nema 7, ATEX, Sanitary, pH Control or Ink System Configurations

Optional Accessories

- | | |
|---------------------------|---------------------------------|
| Single Station Controller | Multi-Station Controller |
| Mounting Brackets | Solenoid Control Valve |
| Viscosity Standards (p52) | Protective Covers for AST-300SY |

TT-100™ Viscometer

for in-line system applications



What's Available?

Rotational, Couette Flow Viscometer in Nema 4, Nema 7 (explosion proof Class I, Division 1 & 2, Group D design), ATEX or Sanitary Configurations

Optional Accessories

- Optional 12V or 24V DC operation
- Readout Indicator
- Variable Speed Motor

Viscosel™ Series

for systems open to the atmosphere



What's Available?

VTE-250 In-Line
Rotational Viscometer

Optional Accessories

- Sample chambers
- Solenoid Control Valve
- Solvent Bottle
- Test Stand
- Mounting Brackets
- Additional Spindles
- Viscosity Standards (p52)

PV-100™ Viscometer

for in-line system applications



What's Available?

PV-100 Rotational
Viscometer in NEMA 4 or
NEMA 7 (explosion proof
Class 1, Division 1 & 2,
Group D design)

Optional Configurations

- PT temperature sensor
- Readout indicator/controller



What's Available?

VTA-120 In-Line Rotational
Viscometer

Optional Accessories

- Sample chambers
- Solenoid Control Valve
- Solvent Bottle
- Test Stand
- Mounting Brackets
- Additional Spindles
- Viscosity Standards (p52)

KV-100™ Viscometer



What's Available?

KV-100 Capillary
Viscometer

Optional Configurations

- Continuous Flow Chamber
- Display Device
- Software

Testing & Consulting

Viscosity Testing Services Available

TEST AND RECOMMEND

A simple evaluation designed to help determine the appropriate Brookfield equipment for your application.

FLUID PROFILING

Analysis testing to determine properties of your fluid sample. We will supply a complete report on the characteristics of your sample.

DISPUTE RESOLUTION

Analysis testing for mediating a resolution between producers and/or suppliers obtaining varying viscosity results of the same material.

MULTIPLE SAMPLE TEST

Expands the capability of your laboratory by utilizing Brookfield's services to accomplish testing work on a timely basis.

Viscosity Test Services are performed for a fee with the exception of "Test and Recommend".

For more information, contact our Rheology Laboratory:
Tel: 800.628.8139 or 508.946.6200, ext. 144
Fax: 508.946.6262
E-mail: testing@brookfieldengineering.com

Methodology Consulting Service On Viscosity Test Development*

A DETAILED REPORT WILL INCLUDE:

- Sample preparation method
- Equipment recommendations
- Controlled shear rate and shear stress tests
- Temperature profiling
- Thixotropic testing
- Material structure recovery evaluation
- Data collection and reporting
- QC viscosity control limit values

For more information, contact our Rheology Laboratory:
Tel: 800.628.8139 or 508.946.6200, ext. 144
Fax: 508.946.6262
E-mail: testing@brookfieldengineering.com

*Note: Consulting Services can also be scheduled to take place at Brookfield's facility in Middleboro, MA



Brookfield's state-of-the-art laboratory offers a variety of viscosity testing services capable of measuring Newtonian and non-Newtonian fluids using a wide range of spindle geometries. Detailed test results include equipment and measurement system description, viscosity data which includes appropriate tables and graphs, and any recommendations pertinent to your specific material and associated method.



The key to successful quality control is designing effective viscosity test methods. Our Methodology Consulting Service brings a Brookfield consulting engineer to your facility to review and recommend appropriate test methods for your materials. We will work with you to define acceptable viscosity behavior taking into consideration relevant shear rates, shear stresses, temperature and time sensitivity issues.

Calibration & Certification

for long life and optimal performance of your Viscometer, Rheometer, Texture Analyzer and Powder Flow Tester

Brookfield Service Center Calibration and Certification

Brookfield Engineering recommends that you return your instrument to Brookfield or an authorized dealer on an annual basis for our Calibration and Certification Service. Please call for a Return Authorization Number.

SPECIAL ARRANGEMENTS:

Loan instruments are available should you need a temporary replacement while your instrument is in for service. Contact Brookfield or an authorized dealer.

Twenty-Four and 48 hour rush service can be arranged. Call for details.

Ball Bearing Retrofit for RV/HA/HB torque range on DV-I Prime, DV-II+ or Pro and DV-III+ or Ultra

SPECIAL INSTRUMENT TESTING PER CUSTOMER SPECIFICATION

When sending your instrument to Brookfield for the Calibration and Certification Service, there may be additional tests that you would like Brookfield to perform. One example is a calibration check using a viscosity standard fluid similar to the one you use in your laboratory. This testing can be requested when the instrument is returned to Brookfield. Complete test results will be included with the instrument when you receive it back at your facility. Our standard hourly rate for lab services will apply.

Contact the Customer Service Department for complete details:
T: 800.628.8139 or 508.946.6200 E-mail: service@brookfieldengineering.com

Outside the United States, contact our authorized representatives. See Pages 89-91 for a comprehensive list.

Brookfield On-Site Service Calibration and Certification*

We now offer On-Site Calibration and Certification Service. Ideal for multiple instrument users, this service allows all your instruments to be serviced at your facility by our trained technician in one convenient visit.

BENEFITS INCLUDE:

- Minimal production disruption
- Reduced down time
- No shipping damage or costs
- Expert on-site advice in preventative maintenance

For more information, contact our Field Service Specialists:
T: 800.628.8139 or 508.946.6200 E-mail: onsite@brookfieldengineering.com

*Note: Spindle straightening not performed on-site. Spindles must be shipped to Brookfield Engineering

IQ, OQ, PQ for Brookfield Products

For those customers in specific industries who need documented validation of installed instrument systems we offer a number of approaches. Call for details or go to www.brookfieldengineering.com.

VISCOSITY STANDARDS FLUIDS should be replaced annually

See pages 52 & 53 for details.

BALL BEARING SUSPENSION OPTION

See pages 50 for details.

EZ-LOCK SPINDLE COUPLING SYSTEM

See pages 50 for details.

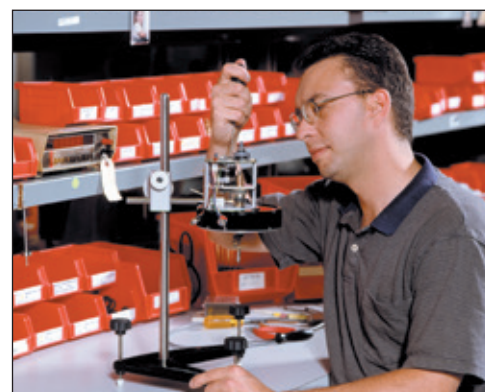

For your viscometers and rheometers, we will inspect your instrument for wear, clean, adjust and lubricate the internal mechanisms, replace part of the sensing system element (the pivot support assembly and, when required, the pointer shaft), and check your spindles. Spindles that are returned to a Brookfield Service Center are also straightened if necessary. In addition to this maintenance, we calibrate and certify in writing that your instrument is operating within proper Brookfield specifications. This certification states that your instrument has been calibrated against standards which are traceable to the National Institute of Standards & Technology (NIST). This is becoming an increasingly important requirement as industry throughout the world takes steps to comply with ISO 9000 regulations.

For texture analyzers, we also inspect for wear, clean, adjust and lubricate internal mechanisms, and adjust, if necessary, the zero and span for proper load cell performance. Certified calibration weights can be purchased for your texture analyzer.

Education



Practical Course on Viscosity Measurements

A single-day course designed to address the major concerns about Brookfield rotational viscosity measurements. At this course, you will learn:

- Principle of Operation: How the viscometer makes measurements
- Calibration: The truth about calibration checks
- Rheology: Why fluids change their flow behavior and why you need to understand it
- Methodology: How to write a method everyone can live with — and use
- Data Interpretation: What all the viscosity data really means

TWO OPTIONS FOR ATTENDANCE ARE OFFERED:

Option #1: At Brookfield, Middleboro, MA

- Provides hands-on lab time, small class size and the opportunity to test your sample

Option #2: At major metropolitan areas

- Regionally located for convenience
- Limited hands-on time with your fluid

Advanced Course on Rheology Test Methods

A single day course designed to use real sample testing data to determine best methodology. At this course you will address:

- Flow behaviors and how to characterize method development
- Controlled stress vs. controlled rate measurements
- Measuring yield stress, creep and recovery of product structure after flow
- Math modeling for advanced data analysis
- Measuring viscosity on-line in your process
- Hands on time with your fluid to develop best practice test methodology

Practical Course on Texture Analysis

A single-day course designed to provide a better understanding of texture analysis as well as the practical use of Brookfield Texture Analyzers. This course addresses:

- Principles of texture analysis
- Considerations for successful instrumental measurements
- An overview of accessories and their applications
- Proper texture testing measurements
- Developing test method

Who are the instructors?

Experienced presenters from the technical staff of Brookfield Engineering Laboratories lead each seminar.

What else?

Customers are encouraged to bring samples of their material for discussion with prior approval.

Course Attendees will receive a course workbook and Brookfield Training Certificate for their training records.

Note: Classes can be presented at the customer's site. Please ask for information regarding this option.

For more information on the schedules or to register for a course, contact the Customer Training Department at Brookfield:

Tel: 800.628.8139 or 508.946.6200

Fax: 508.946.6262

E-mail: edu@brookfieldengineering.com

Help & Resources

Feeling overwhelmed? Our Customer Service or Technical Sales Departments can help guide you toward the proper instrumentation and measuring technique for your application. We also offer courses, free technical papers, and a website full of videos, application notes, and manuals.

Frequently asked questions

YOU MAY WANT TO REVIEW THESE BEFORE CALLING FOR ASSISTANCE.

I've read page 7 regarding model selection, and I've reviewed the models available to me, but I'm still unsure — can you test my product for me?

Brookfield has a test and recommend service wherein we will test your sample and make a product and method recommendation to help get you up and running. Please call us for details.

Do I need an accessory?

There are no firm rules for determining when an accessory is required. If your test method is not already established within your company, we recommend calling Brookfield so that we may review the best choices available for your specific application. As a general guideline, you may want to consider and discuss with us the accessories shown in [blue](#) if any of the following apply to your situation:

- The product is similar to the consistency of water.
[Consider: UL Adapter](#)
- The product is similar to the consistency of peanut butter.
[Consider: Helipath Stand](#)
- The product has suspended solids, similar to relish.
[Consider: vane spindles](#)
- The product sample is limited.
[Consider: Small Sample Adapter accessory or Cone/Plate Viscometer](#)
- The product must remain at a consistent temperature.
[Consider: TC series water bath](#)
- The product is wax-like and needs to be melted at a high temperature just like asphalt
[Consider: Thermosel](#)
- The product is very paste-like similar to solder paste.
[Consider: Spiral Adapter or R/S Rheometer](#)

Do I need software?

Our software provides an easy way to gather data, plot graphs, export data to Excel and should be considered if detailed records are needed or if you want a more automated process. Software is also ideal for multiple operators and complex or repetitive testing.

Do I need a viscosity standard and when should it be replaced?

Yes, verification of instrument calibration with a viscosity standard should be done periodically to ensure that your instrument is in calibration and providing reliable results. We typically recommend replacement of standards every 6-12 months depending on the frequency of use and material tested.

Is verifying calibration the same as the yearly calibration service that Brookfield recommends?

No, verifying calibration is performed by you using viscosity standard fluids in accordance to the procedure outlined in the instrument's operator manual. Our Calibration & Certification Service is similar to getting your car's oil changed and a tune-up. You return your instrument to us, and we clean, adjust and lubricate the internal mechanism. We also replace part of the sensing system when necessary, and certify that the instrument is working properly in compliance with ISO 9000 regulations.

Other Educational Resources

SEMINARS

Our popular Practical Course on Viscosity Measurements seminar is ideal for someone new to viscosity. This single-day class includes an overview of viscosity, measurement method discussions and hands-on testing to demonstrate what is being learned in the classroom session. A brief overview on Brookfield Viscometers and accessories is part of the curriculum and may also be helpful to those who have yet to choose an instrument. A similar course is also offered for texture analysis.

VIDEOS, APPLICATION NOTES AND OTHER PUBLICATIONS

Online help is available 24/7 on the Brookfield website: www.belusa.com. Navigate to the EDUCATION tab for a more in-depth discussion on viscosity, rheology, texture and powder flow as well as helpful videos, more frequently asked questions, product instruction manuals, a calibration template and many other technical publications.

3A

A US industrial standard for process equipment design; required certification for clean-in-place capability.

Absolute Viscosity

The viscosity value associated with a Newtonian material

Angle of Wall Friction

Represents the friction between the sliding powder and the wall of the hopper or chute at the onset of flow

Arching Dimension

Minimum hopper outlet size needed to insure that the powder will discharge in Mass Flow instead of forming a stable arch across the opening.

ASTM

American Society of Testing and Materials

Autorange

Maximum viscosity value that can be measured using a specific spindle at a designed rpm.

Bob

spindle used with PVS and R/S series rheometers; also referred to as “bob/stator” because it does not rotate on this instrument. The sample cup rotates instead, causing the shearing action.

Bulk Density

The mass of the powder divided by its total volume

Cohesion

A measure of the strength retained by a powder after it has been compacted to a given consolidation level

Concentric Cylinder

A cylinder within a cylinder. For viscosity measurement, a cylindrical spindle rotates within a cylindrical chamber. Also known as “Coaxial Cylinder” because both cylinders have the same center line.

Consolidation

The process of applying a normal and a shear stress to a bulk solid to move the particles together in order to observe any increases in its cohesion, bulk density, etc.

Core-Flow

A first in-last out discharge pattern where the powder flows from the top of the vessel through a vertical channel above the outlet. Powder that is near the walls of the vessel remain stagnant until the level descends to the point where the powder is at the top surface.

dyne•cm

A unit of measurement for torque.

Gap

The distance between the spindle and the chamber or cup in which the spindle is rotating.

Hopper Half Angle

Maximum angle of the converging hopper wall (from the vertical axis) to insure mass flow. Angles greater (shallower) than this will produce core flow.

In-line

Process viscometer placement in a pipe.

Loose Fill Density

The bulk density of the powder in the trough before any stress is applied.

Mass Flow

A first in-first out discharge pattern where the powder flows at the vessel walls and all the material is in motion.

NIST

National Institute of Standards and Technology. US Government organization for test standards.

Newtonian

a material whose viscosity value is the same at all shear rates (e.g. water, honey).

Non-Newtonian

A material whose viscosity changes as shear rate changes (shampoo, mayonnaise).

On-line

Use of a process viscometer to provide continuous viscosity measurement of a material.

Pneumatic

Air operated

PP

Plate and plate geometry.

Rathole Diameter

Minimum outlet diameter of a core flow hopper needed to insure that the powder will flow instead of forming a stable rathole.

Relative Viscosity

The viscosity value of a non-Newtonian material at a defined shear rate.

RPM

Rotations per minute; a unit of measurement for spindle speed.

RTD

Resistance thermal detector; type of sensor for measuring temperature

sec⁻¹

The scientific unit of measurement for shear rate; expressed as “reciprocal seconds” or “inverse seconds.”

Shear Rate

The velocity gradient in a flowing material; the shape and rotational speed of the spindle rotating in a chamber or cup are used to calculate shear rate.

Shear Stress

The force per unit area used to move a material.

Spindle Geometry

The shape of a spindle. Brookfield spindles supplied with standard Viscometers/Rheometers (Dial Reading, DV-E, DV-I Prime, DV2T, DV3T) are disc type. Other choices include Cylindrical, Cone, Plate, KREBS, etc.

Torque Range

The torque measurement capability of a Brookfield Viscometer/Rheometer measured in dyne•cm; designations such as LV, RV, HA or HB are used to define the Torque Range for a specific instrument.

Torque %

The amount of torque resistance measured by a rotating spindle immersed in a material.

Yield Stress

The amount of force required to cause a material to flow.

Conversion Tables

Viscosity

1 cP	=	1 mPa•s
1 P	=	100 cP
1 Pa•s	=	1,000 mPa•s

Sample Volume

1 L	=	1000 mL
1 mL	=	1000 µL
1 gal	=	8 pt. = 3.7 L
1 pt	=	16 oz.

Torque Range

LV	=	673.7 dyne•cm
RV	=	7,187 dyne•cm
HA	=	14,374 dyne•cm
HB	=	57,496 dyne•cm
5xHB	=	287,480 dyne•cm
1N•m	=	10 ⁷ dyne•cm

Temperature

°C	=	$\frac{5}{9} (^{\circ}\text{F}-32)$
----	---	-------------------------------------

Texture

1 Kg	=	1000 g
1 Kg	=	9.8 N
1 inch	=	2.54 cm
1 cm	=	10 mm

Please refer to Brookfield’s publication “More Solutions to Sticky Problems” for a detailed explanation of viscosity and Brookfield methodology for making measurements.

POLAND

LABO PLUS LTD. **L T P P**
Warszawa, Poland
Tel: (48) 22/646-7727
E-mail: laboplus@laboplus.pl
Website: www.laboplus.pl

PORTUGAL

SOQUÍMICA **L T P P**
Lisboa Porto, Portugal
Tel: (351) 21/711 9300
E-mail: soquimica@soquimica.pt
Website: www.soquimica.pt

PUERTO RICO

PUERTO RICO PROCESS TECHNOLOGY, INC. **L T P P**
Fajardo, PR
Tel: (787) 801-4483
E-mail: jgwt@coqui.net

ROMANIA

MULTI LAB SRL **L T P P P**
Bucharest, Romania
Tel: (40) 21/312-7144
E-mail: contact@multilab.ro
Website: www.multilab.ro

RUSSIA

AVRORA LTD. **L T P P**
Moscow, Russia
Tel: (7) 495 258-8305
E-mail: avrora@com2com.ru
Website: www.viscometer.ru

ARGOSY TECHNOLOGIES LTD. **P**
Moscow, Russia
Tel: (7) 095 510-6236
E-mail: moscow@argosy-tech.ru
Website: www.argosy-tech.ru

SAUDI ARABIA

K. I. ABDULKADIR & PARTNERS CO. LTD. **L T P P**
Jeddah, Saudi Arabia
Tel: (966) 12/640-5846
E-mail: info@kiaksa.com
Website: www.kiaksa.com

NAIZAK GLOBAL ENG. SYSTEMS **P**
Al-Khobar, Saudi Arabia
Tel: (966) 3/897-4721
E-mail: sigedaap@naizak.com
Website: www.naizak.com

SERBIA, MONTENEGRO

SUPERLAB **L T P P**
Belgrade, Serbia
Tel: (381) 11/222-2222
E-mail: superlab@super-lab.com
Website: www.super-lab.com

SINGAPORE

MECOMB SINGAPORE LIMITED **L T P P**
Singapore
Tel: (65) 6572-1200
E-mail: enquiry.msl@simedarby.com.sg
Website: www.simedarbyenergyutilities.com

PRECISION CONTROL PTE. LTD. **P**
Singapore
Tel: (65) 6285-3011
E-mail: sales@pcsin.com.sg
Website: www.precisioncontrol.com.sg

SLOVAK REPUBLIC

ECOTEST, S.R.O. **L T P P**
Topolcany, Slovak Republic
Tel: (421) 38/532-0171
E-mail: ecotest@isternet.sk
Website: www.ecotest.sk

SLOVENIA/CROATIA/ BOSNIA-HERZEGOVINA

LABSYS, D.O.O. **L T P P P**
IG-Ljubljana, Slovenia
Tel: (386) 1/286-2330
E-mail: labsys@labsys.si
Website: www.labsys.si

SOUTH AFRICA

MONITORING & CONTROL LABORATORIES (PTY) LTD. **L T P P**
Johannesburg, South Africa
Tel: (27) 11/608-4664
E-mail: sales@moncon.co.za
Website: www.moncon.co.za

WIRSAM SCIENTIFIC & PRECISION EQUIPMENT (PTY) LTD. **P**
Johannesburg, South Africa
Tel: (27) 11-482 1060
E-mail: wirsamjb@wirsam.com
Website: www.wirsam.com

SPAIN

INSTRUMENTACION ANALITICA, SA **L T P P P**
Barcelona, Spain
Tel: (34) 93 478 71 61
E-mail: barcelona@instru.es
Website: www.instru.es

SRI LANKA

HEMSONS INTERNATIONAL (PTE) LTD **L T P P**
Colombo, Sri Lanka
Tel: (94) 11/232-3308
E-mail: hemasl@sit.lk
Website: www.hemsons.lk

SWEDEN

CHEMICAL INSTRUMENTS AB **L T P P**
Sollentuna, Sweden
Tel: (46) 8/5448-1260
E-mail: info@ciab.se
Website: www.ciab.se

TEAMATOR AB **P**
Helsingborg, Sweden
Tel: (46) 42-250357
E-mail: info@teamator.com
Website: www.teamator.com

SWITZERLAND

HUNTER & CAPREZ AG **L T P P P**
Zumikon, Switzerland
Tel: (41) 44/918-0808
E-mail: mail@huntercaprez.com
Website: www.huntercaprez.com

TAIWAN

TODAY'S INSTRUMENTS CO., LTD. **L T P P P**
New Taipei City, Taiwan, R.O.C.
Tel: (886) 2/2603-2311
E-mail: todays@todays.com.tw
Website: www.todays.com.tw

THAILAND

PRECISION CONTROL (THAILAND) CO. LTD. **P**
Bangkok, Thailand
Tel: (66) 2/910-5280
E-mail: sales@pc-thai.com
Website: www.pc-thai.com

SCIENTIFIC PROMOTION CO., LTD. **L T P P**
Bangkok, Thailand
Tel: (66) 2/185-4333
E-mail: marketing@spcgroup.co.th
Website: www.spcgroup.co.th

TURKEY

ARIF SALTUK LTD. STI. **P**
Istanbul, Turkey
Tel: (90) 212/233-9504
E-mail: arifsaltuk@superonline.com
Website: www.arifsaltuk.com

SEM ENDÜSTRİ CIAZLARI A.S. **L T P P**
Istanbul, Turkey
Tel: (90) 216/325-7836
E-mail: info@semend.com.tr
Website: www.semend.com.tr

UKRAINE

TEC ENGINEERING LTD. **L T P P**
Kiev, Ukraine
Tel: (380) 44/496-2690
E-mail: office@tec.com.ua
Website: www.tec.com.ua

UNITED ARAB EMIRATES, OMAN, QATAR, KUWAIT, YEMEN

VENKTRON ELECTRONICS L.L.C. **L T P P P**
Sharjah, United Arab Emirates
Tel: (971) 6/532-9797
E-mail: venk@eim.ae
Website: www.venktron.com

UNITED ARAB EMIRATES, OMAN, QATAR, KUWAIT (oil and gas only)

CONTROL & APPLICATIONS TECHNOLOGY SOLUTIONS **P**
Abu Dhabi, United Arab Emirates
Tel: (971) 2/676-7965
E-mail: roman.briceno@catsmea.com
Website: www.catsmea.com

UNITED KINGDOM

BROOKFIELD VISCOMETERS LIMITED **L T P P**
Harlow, Essex, England
Tel: (44) 1279/451774
E-mail: sales@brookfield.co.uk
Website: www.brookfield.co.uk

FULLBROOK SYSTEMS LIMITED **P**
Herts, England
Tel: (44) 1-442-876777
E-mail: sales@fullbrook.com
Website: www.fullbrooksystems.co.uk

URUGUAY

ALDENOR SA **L T P P**
Montevideo, Uruguay
Tel: (598) 2/916-9857
E-mail: info@aldenor.com.uy
Website: www.aldenor.com.uy

VENEZUELA

CORPORACION CIENTIFICA VENEZOLANA C.A. **L T P P**
Caracas, Venezuela
Tel: (58) 212/761-5221
E-mail: ventas@ccv.com.ve
Website: www.ccv.com.ve

DIDACTA, C.A. **L T P P**
Caracas, Venezuela
Tel: (58) 212/278-5811
E-mail: didactaimport@intercable.net.ve
Website: www.didacta.com.ve

VENEZUELA

NORTHLAND AUTOMATION SERVICES LLC **P**
Miami, FL 33172
Tel: (1) 305-513-3718
E-mail: giannella.manzanero@northlandautomation.com
Website: www.northlandautomation.com

VIETNAM

VIETCO SCIENTIFIC & TECHNICAL EQUIPMENT CO. LTD. **L T P P**
Hochiminh City, Vietnam
Tel: (84) 8/6650-3700
E-mail: vietco.scientific@gmail.com

RONG TIEN CO., LTD **L T P P P**
Hochiminh City, Vietnam
Tel: (84) 8/3816-4708
E-mail: rongtien@rongtien.com
Website: www.rongtien.com

Brookfield Regional Offices

Brookfield Viscometers Limited

Brookfield Technical Centre
1 Stadium Way
Harlow, Essex CM19 5GX, England
Tel: 1279/451774
Fax: 1279/451775
E-mail: sales@brookfield.co.uk
Website: www.brookfield.co.uk

Brookfield Engineering Labs.

Vertriebs GmbH
Hauptstrasse 18
D-73547 Lorch, Germany
Tel: 7172/927100
Fax: 7172/927105
E-mail: info@brookfield.eu
Website: www.brookfield.eu

RheoTec

Messtechnik GmbH
a division of Brookfield Engineering
Schutterwälder Straße 23
D-01458 Ottendorf-Okrilla
Tel: 03 52 05/59 67-0
Fax: 03 52 05/59 67-30
E-mail: info@rheotec.de
Website: www.brookfield.eu

Guangzhou Brookfield Viscometers and

Texture Instruments Service Co. Ltd.
Suite 905-906, South Tower, Suntec Plaza, 193
Guangzhou Da Dao Bei Road
Yuexiu District Guangzhou, Guangzhou, P.R.C.
510075
Tel: (86) 20/3760-0995; -8953
Fax: (86) 20/3760-0548; -8953
E-mail: info@brookfield.com.cn
Website: www.brookfield.com.cn

Brookfield Engineering Laboratories, Inc.

Midwest Regional Office
8 North Maple Street
Mt. Prospect, IL 60056 USA
Tel: (847) 368-8472
E-mail: d_larson@brookfieldengineering.com
Website: www.belusa.com

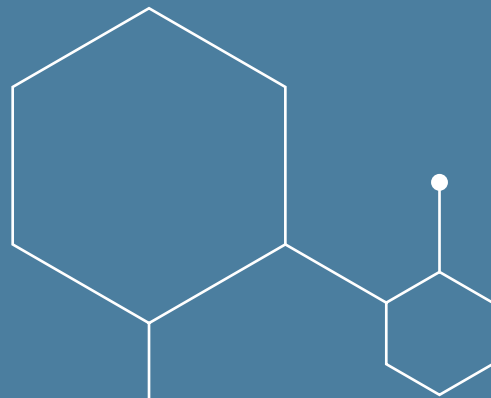
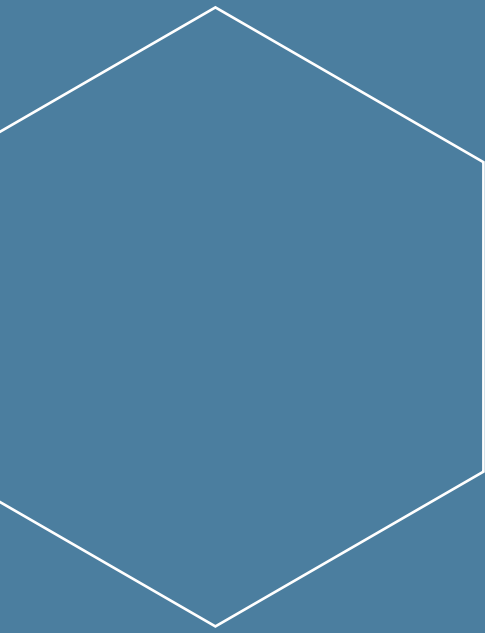
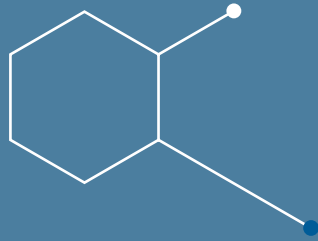

Brookfield Engineering Laboratories, Inc.

11 Commerce Boulevard, Middleboro, MA 02346-1031 USA

T (800) 628 8139 or (508) 946 6200

F (508) 946 6262

www.brookfieldengineering.com